

UNESCO-IHE
Institute for Water Education



Systems Analysis of Zaragoza Urban Water System (Spain): A Preliminary Assessment of Environmental Sustainability

Guillermo Penagos

MSc Thesis ES 07.27
April, 2007



Systems Analysis of Zaragoza Urban Water System (Spain): A Preliminary Assessment of Environmental Sustainability

Master of Science Thesis

By

Guillermo Penagos

Supervision

P. N. van der Steen, PhD, MSc (UNESCO-IHE)

Examination Committee

Prof K. Vairavamorthy (UNESCO-IHE), Chairman

P. N. van der Steen, PhD, MSc (UNESCO-IHE)

R de Graaf, MSc (external)

This research is done for the partial fulfilment of the requirements for the Master of Science degree at UNESCO-IHE Institute for Water Education, Delft, the Netherlands

Delft

April, 2007

Abstract

The environmental performance of Zaragoza urban water system of (Spain) is analyzed by means of LCA with focus on water withdrawal and use; energy and chemical products consumption; CO₂ emissions; and emissions of nutrients and heavy metals to the receiving water body and to sewage sludge. All these variables are recommended to be used as indicators for sustainability of this urban water system. The time horizon covers six years between 2000 and 2006; a period where the water supply system is being optimized and industrial and water consumption is being reduced. Results show that despite a significant reduction of water withdrawal and unaccounted, resource consumption and final releases to the environment have remained steady. Groundwater is an important component of the urban water cycle, but due to its origin as agriculture irrigation excess is facing issues of quality. This resource will be possibly threatened in the future if irrigation systems upstream from Zaragoza are optimized. A problem tree analysis revealed that mayor drivers of environmental sustainability for Zaragoza water cycle are population increase; Spanish national policies on water and environment and climate change. A scenario analysis showed that industrial recycling would be a good strategy to continue reducing water withdrawal and it will also contribute to reduce energy consumption as well as CO₂ emissions, whereas all other analyzed indicators are expected to worsen as long as current societal production and consumption patterns; and wastewater treatment technologies remain the same. Comprehensive strategies that involve not just technical solutions are required in order to assure the environmental sustainability of this system.

Keywords: Environmental performance, Life cycle assessment, sustainability indicators, urban water systems, pollution loads, resource consumption, scenario analysis.

Acknowledgements: This report is the result of research to the M Sc Programme in Environmental Science of the UNESCO-IHE Institute for Water Education, financed by the Programme Alβan – European Union Programme of High Level Scholarships for Latin America (no. E05M054643CO); and the UNESCO-IHE Fellowship Trust Fund. This research is part of the SWITCH project funded by the FP 6 programme of the European Union (no. 018530).

Table of Contents

Abstract	3
Acknowledgements	3
Table of contents	4
List of figures	5
List of tables	6
List of annexes	6
Abbreviations	7
1. Introduction	8
2. Background	9
3 Materials and Methods	15
3.1 Study site	15
3.2 General Approach	16
3.2.1 Developing flow diagram	17
3.2.2 Time horizon	17
3.2.3 Data collection	17
3.2.4 Data analysis	18
3.2.4.1 Storm water	18
3.2.4.2 Energy consumption and CO ₂ emissions from transportation	18
3.2.4.3 CO ₂ Emissions from electricity consumption	19
3.2.4.4 CO ₂ production from sludge	19
3.2.5 Scenario analysis	19
4 Results	20
4.1 Data availability and information gaps	20
4.2 . General features of Zaragoza UWS	20
4.2.1 Water inputs	23
4.2.1.1 Tap water source	23
4.2.1.2 Storm water	24
4.2.1.3 Agriculture irrigation systems	25
4.2.1.4 Ground water	26
4.2.2 Drinking water treatment	26
4.2.3 Distribution network	27
4.2.4 Water use	28
4.2.5 Sewer system	30
4.2.6 Wastewater treatment	31
4.3 Environmental performance of Zaragoza UWS	32
4.3.1 Use of chemical products	32
4.3.2 Energy consumption and Atmospheric emissions	34
4.3.3 Heavy metals	37
4.3.4 Organic matter	38
4.3.5 Nutrients	38
4.3.6 Sludge production	42
4.4 Zaragoza UWS in the future	42
4.4.1 Focus problem and drivers affecting Zaragoza sustainability vision	43
4.4.1 Criteria for classification of drivers	44
4.4.1.1 Less important – less uncertain	44
4.4.1.2 Less important – more uncertain	45
4.4.1.3 More important – less uncertain	45
4.4.1.4 More important – more uncertain	46
4.4.3 Scenario analysis	47
4.4.3.1 Setting Scenario	47
4.4.3.2 Assumptions for Scenario analysis	47
4.4.3.3 Suggested strategy: Industrial water recycling	48
4.4.3.3.1 Effect of water recycling on water withdrawal	48
4.4.3.3.2 Effect of water recycling on chemical products consumption	49

4.4.3.3.3	Effect of water recycling on Energy consumption	50
4.4.3.3.4	Effect of water recycling on CO ² emissions to the atmosphere	51
4.4.3.3.5	Effect of water recycling on pollution loads to the Ebro River	52
4.4.3.4	Assessment of water quantity and quality for Zaragoza in the future	52
4.4.3.5	Setting priorities for pollution loads	54
5	Discussion	59
5.1	Sustainability of UWS	59
5.2	LCA as a tool for Sustainability assessment	60
5.3	Sustainability Indicators	60
5.4	Sustainability vision	63
5.5	Drivers for sustainable urban water planning and management	65
5.6	Set vs achieved goals for this research	68
6	Conclusions	69
7	References	71

List of figures

Figure 1.	Satellite map for Zaragoza and its location in Spain	15
Figure 2.	Flow Diagram for Zaragoza UWS.	22
Figure 3.	Ebro river discharge at “Canal Imperial” diversion	23
Figure 4.	Annual precipitation hydrographs for Zaragoza.	24
Figure 5.	Irrigation in Zaragoza province.	25
Figure 6.	Scheme of a breaking pressure tank	30
Figure 7.	Chemical products consumption by Zaragoza UWS. Chlorine, Allum and PAC are used for DWT whereas Iron Chloride is used for WWT in “Carjuja”plant	33
Figure 8.	Energy consumption of Zaragoza’s UWS per process.	35
Figure 9.	Current Sources of Electric Energy in Spain.	36
Figure 10.	Direct and Indirect CO ₂ emissions of Zaragoza’s UWS	37
Figure 11.	CO ₂ emissions of Zaragoza’s UWS per process.	37
Figure 12.	Heavy metals in Zaragoza waste water	38
Figure 13.	Heavy metals loads to the environment from Zaragoza UWS.	40
Figure 14.	BOD and COD loads from Zaragoza’s UWS to the Ebro River	40
Figure 15.	Nitrogen loads to the environment from Zaragoza UWS.	41
Figure 16.	Phosphorus to the environment from Zaragoza UWS.	41
Fig 17.	Sludge (as dry matter) production by Zaragoza UWS	42
Figure 18.	An exercise of problem tree analysis for Zaragoza. The core problem would be to	44
Figure 19.	Matrix of uncertainty vs importance to classify drivers of Zaragoza UWS sustainability	44
Figure 20.	Composition of electric power production market in Spain projected by 2015 by National Plan on Energy	46
Figure 21.	Water withdrawal discriminated by actual consumption and unaccounted water under Sc3 scenario and different strategies for water reuse	49
Figure 22.	Energy consumption of Zaragoza UWS in 2006 and 2020 scenario with different levels of Industrial water recycling strategy	50
Figure 23.	CO ² emissions from Zaragoza UWS in 2006 and 2020 scenario with different levels of Industrial water recycling strategy	51
Figure 24.	Current and projected water storage regimes for Yesa reservoir on a hydrologic	53
Figure 25.	Regimes for Ebro River at Zaragoza under current conditions and projected conditions under Sc3 Scenario.	54
Figure 26.	Impact of Zaragoza UWS upon TP concentrations at the Ebro River.	55
Figure 27.	Seasonal variability of impact percentages of Zaragoza UWS on the Ebro River taking TP as example. Current and future scenarios.	56

List of tables

Table 1. Zaragoza's Primary Distribution System. Current situation	27
Table 2. Evolution of water withdrawal and consumption in Zaragoza	29
Table 3. Classification of industrial discharges in Zaragoza in 2005	31
Table 4. Zaragoza public WWTPs	32
Table 5. Goals of the Aalborg summit that apply to the UWS of Zaragoza	43
Table 6. Possible drivers scenarios for Zaragoza UWS	47
Table 7. Seasonal impact peaks of Zaragoza UWS upon the Ebro River under present conditions and worst climate change scenarios for 2020 and 2060.	58

List of annexes

Annex 1. Inventory for data necessary to perform LCA and its availability in Zaragoza	
Annex 2. Raw Data for the Drinking Water Treatment Plant of Zaragoza on monthly basis	
Annex 3. Raw Data for Energy Consumption of the Water Distribution Network in Zaragoza	
Annex 4. Groundwater flows and energy consumed for groundwater extraction	
Annex 5. Raw Data for "Cartuja" WWTP	
Annex 6. Raw Data for "Almozara" WWTP	
Annex 7. Raw Data for "Paper mills" WWTP	
Annex 8. Calculations of CO ₂ emissions from electricity consumption	
Annex 9. Calculation of Environmental Impacts from Transportation	
Annex 10. Calculations for Storm water overflows to the Ebro River	

Abbreviations

BOD	Biological Oxygen Demand
COD	Chemical Oxygen Demand
CHE	Ebro River Hydrographic Confederation
CO ₂	Carbon dioxide
DBPs	Disinfection By-products
DOM	Dissolved Organic Matter
DWT	Drinking Water Treatment
DWTP	Drinking Water Treatment Plant
Gwh	Giga watt per hour
EU	European Union
GIS	Geographic information system
Ha	Hectare
LCA	Life Cycle Analysis
LCI	Life Cycle Inventory
mg l ⁻¹	milligrams per liter
µg l ⁻¹	micrograms per liter
mm	millimeters
m ³	cubic meters
m ³ year ⁻¹	cubic meters per year
Mwh	Mega watt per hour
l person ⁻¹ day ⁻¹	liters per person per day
OM	Organic Matter
PAC	Powdered Activated Carbon
SD	Sustainable Development
SDI	Sustainable Development Indicator
SFA	Substance Flow Analysis
SS	Suspended Solids
TN	Total Nitrogen
TP	Total Phosphorus
UW	Urban Water
UW	Urban Water System
WWT	Wastewater Treatment
WWTP	Wastewater Treatment Plant

1 Introduction

Approximately half of the world's population is nowadays living in cities. This percentage is increasing and so is doing their demand for natural resources as well as their pollution loads to the environment. It is reasonable to assume that if cities can become sustainable then society as a whole will follow the tendency. A key aspect on sustainability of the cities is the urban water system (UNESCO, 1999; Hellstrom et al, 2004).

A sustainable urban water system should provide its services while protecting human health and the environment, with an optimum use of scarce resources over a long term perspective (ASCE, 1998). There is a strong need of developing and implementing indicators that make the concept measurable by quantifying trends towards optimization, not just of existing water and wastewater technologies but of urban societies as a whole (Larsen and Guier, 1997).

Along the whole urban water cycle, important impacts on the environment take place: water is consumed, as well as energy and chemical products. On the other hand organic matter, nutrients and persistent pollutants are entering the ecosystems. A quantification of all these negative effects upon the environment is considered to be a good indicator of environmental sustainability (Larsen and Guier, 1997; Varis and Somlyody, 1997; Lundin; 1999).

This study aims to analyze the environmental performance of Zaragoza Urban Water System in Spain with regard to the use of natural resources and pollutant loads to the environment. The use of natural resources is assessed with regard to water withdrawal as well as energy and chemical products consumption. Considered pollution loads are atmospheric emissions, oxygen demands to the river, nitrogen, phosphorus and heavy metals. Such analysis will serve as baseline information for further assessment of sustainable development. This research work only deals with the operational aspects of the UWS and does not include construction, upgrading and demolition of infrastructure.

The present research is included within the SWITCH project framework, program 1 which aims to assess the adjustability of Urban Water Systems to global change pressures from a strategic approach based on sustainability and risk assessment.

2 Background

Sustainability of Water resources is a concept that concerns all levels of planning and management, from local to global agendas. Since cities are major water consumers, sustainability of urban water systems is increasingly becoming a major issue, receiving considerable effort from researchers and managers in both developed and developing countries (Larsen and Guier, 1997; Varis and Somlyody, 1997; Lundin, 1999).

Several research projects have taken place during the last decade, mostly in European Countries. But there are also international partnerships which have included studies upon model cities in Africa and Asia. The Swedish Urban Water Project Mistra deserves special recognition since it produced numerous publications, PhD thesis and reports concerning several aspects of Urban Water Systems not just for European, but also to Asian and African cities such as Calcutta and Cairo (Hellstrom et al, 2004). Approaches similar to Mistra are taking place at different scales in Australia, Germany, and Belgium (Lundie et al, 2004).

Assessing sustainability of Urban Water Systems is a major task considering the high complexity of such a system. Decision-making needs to consider several aspects of health, environment, economy, socio-culture and technical function within a framework that includes interactions between users, organizations and technology. Important issues compromising sustainability in all these aspects are the efficient use of water and energy, the assessment for microbial risk, nutrient recycling and the emission toxic substances to the environment (Malmqvist and Palmqvist, 2005, Jeppson and Hellstrom, 2002).

The efficient use of water and energy is related to all processes taking place in the Urban Water System, the microbial risk is of primary concern for drinking water supply, nutrient recycling and toxic substances are related to wastewater treatment and sludge disposal. Nevertheless, several studies have proven that untreated storm water is a major responsible for hazardous emissions coming from cities. This fact along with the well known risks related to floods has increasingly turned the attention towards planning and management of storm water as a key element for Urban Sustainability (Jeppson and Hellstrom, 2002)

There is a need of information tools that serve to evaluate this complexity and search for alternatives that make the concept of sustainability fully operational for the Urban Water System. Initial interest of researchers and decision makers in this regard was to produce ad hoc Indicators for Sustainable Development (Lundin and Morrison, 2002)

A large number of indicators are used by water and waste water organizations to assess their technical performance. Such indicators may differ between different organizations and different countries. The results are large amounts of data, difficult to understand and to interpret. Besides only few of those indicators have been developed to quantify sustainability. There is still a need for a limited number of sustainability indicators for urban water systems (Lundin, 1999).

One of the main problems of quantifying sustainability is the lack of a structured methodology to develop indicators, with the consequent risk that such indicators would be ineffective and, possibly detrimental in promoting sustainability objectives (Lundin and Morrison, 2002). Therefore, recent studies have based on Systems Analysis Approach and have used techniques related to the concept of industrial ecology, such as Material Flow Analysis and Life Cycle Assessment. When properly followed, those techniques have proven to be quite effective to evaluate environmental performance of Urban Water Systems. Some authors have concluded that such techniques are needed as a basis for all other studies concerning Urban Water Systems because the flows, the major sources and the fate of water and its major constituents such as nutrients, pathogens and harmful chemicals, must be clear for all alternative management strategies (Ahlman, 2006; Benedetti et al., 2005; Lindqvist and Malmborg, 2004).

LCA analysis is suggested to be a comprehensive technique to assess environmental sustainability of UWS. The term "Life cycle" refers to the major activities in the course of a product lifespan from its manufacture, use and maintenance, to its final disposal, including the raw material acquisition required to manufacture the product. Impacts related to outputs will be emissions to different environmental compartments (Lundin and Morrison, 2002).

The main advantage of LCA is that it can contribute to evaluate the impacts upon different environmental compartments, preventing the implementation of management

options that, in the search for mitigation, end up by shifting pollution from one place to another. This is the trade-off of for instance, the alternative of nutrient recycling from wastewater treatment sludge, which will protect the receiving water body, but can constitute a further risk for arable land protection, since such sludge may contain not just nutrients, but also heavy metals, being also a further risk for food security (Malmqvist & Palmqvist, 2005).

During the last decade there have been many research works using LCA to assess urban water systems. One of the major problems faced by this technique is the definition of system boundaries. Many choices can be made in terms of time horizon, geographic borders as well as functional boundaries. Results will be very much affected by such choices, being often not comparable. For instance most studies have focused on either water supply or on WWT systems.

Crettaz et al. (1997) evaluated different alternatives for alternatives drinking water distribution and treatment as well as wastewater treatment. They also assessed on-site alternatives such as rainwater storage, sewage separation and water-saving toilets. Authors found that rainwater use was not favorable in terms of energy consumption and also it would lead to a higher contamination of heavy metals to water and soils.

Roeleveld et al. (1997) performed an LCA of different conventional wastewater treatment methods in at a national level in the Netherlands. The authors concluded that to improve the sustainability, the discharge of emissions should be reduced from the effluent. Energy use, construction and the use of chemicals were considered less important as compared to the operation of the system.

Matsubishi et al. (1997) compared different sludge treatment processes: landfilling, incineration, ozonation and composting. One conclusion the authors draw was that when sludge is used to improve soil fertility, the benefit should be compared with an LCA for production and use of chemical fertilizer.

Neumayr et al. (1997) compared six different alternatives for sludge recycling strategies. Authors found that energy consumption, fossil fuels used for transportation and direct

emissions from composting and dewatering were the most significant impacts. Anaerobic treatment showed lower energy consumption than aerobic digestion.

Swage management alternatives in contraposition form end-of-pipe technologies were evaluated by Bengtsson et al., (1997) compared conventional wastewater systems with liquid composting and urine separation. The study showed that the separation system has lower pollution loads to water and is more efficient for nutrient recycling than conventional systems.

Only few studies have addressed the whole urban water cycle (Lassaux et al, 2005) and even with similar choices of system boundaries, the outcomes might be contrasting. Some publications give more importance to energy and chemical consumption, other stress groundwater withdrawal, other suggest that more attention should be given to pollution burdens (nutrients, BOD, heavy metals, etc). Results will differ from each other depending on the scale of the system, the economic development of the city subjected to study, the external activities that are considered and even the base unit for impact calculation: per year, per person and per year, per cubic meter of water.

System Boundaries should be chosen according to the purpose of the study (Lundin and Morrison, 2002), but LCA is aimed to avoid planning and operation alternatives that improve environmental performance of one sub process but worsen other part of the cycle. In principle an LCA should include as many upstream and downstream externalities associated with the system as possible.

Upstream activities considered in LCA studies of UWS largely focus on chemical use for both drinking and waste water treatment, energy consumption and atmospheric emissions related to transporting chemicals from producers to water facilities should be included within system boundaries. A more comprehensive approach would also include energy consumption and hazardous emissions related to the production of such chemicals (Lassaux et al., 2005; Lundie et al., 2004)

Most evident downstream activity of a UWS is WW discharge. Most LCA studies also focus on sludge production and final disposal. Water recovering, nutrient recycling and minimizing hazardous emissions are the main subject here. Once again energy

consumption and atmospheric emissions derived from sludge disposal are suggested to be included within system boundaries.

Another important question concerning system boundaries is water infrastructure. The usual time perspective to plan and construct a UWS is of several decades. But sustainability is a long term concept, therefore a time horizon projection of about 100 years is suggested. The construction of the water supply also may have significant environmental impacts which can be quantified such impact on the basis of the mass of material needed to construct the pipes, considering lengths, diameters and comparing different materials. Environmental Impact of putting pipes into the ground may also be considered (Lundin & Morrison, 2002)

Lassaux et al. (2005) found infrastructure construction as having a significant contribution to the overall environmental impacts of the UWS. This is very important since improving WWT systems will increase environmental impacts in one way, because materials are used for construction, and then chemicals and energy are consumed. The authors also found that construction phase is responsible for important environmental impacts before tap (withdrawal pipeline, drinking water treatment, and distribution network) have less impact than stages after tap (sewer system and WWTP). In fact sewer network construction was the factor that contributed the most to the global environmental load of the anthropogenic water cycle from the Wallon region in Belgium. In contrast, Lundie et al. (2004) found infrastructure construction to contribute with less than 4% of all different categories of burdens to the environment, for both present conditions and alternative future scenarios of Sydney's UWS.

Lundie et al. (2004) used an LCA approach for assessing alternative future scenarios for strategic planning of Sydney's UWS with a high degree of segmentation within the system. In order to select the best environmental performance different alternatives were classified after LCA in two categories: (1) options that improve the overall environmental performance and (2) options that improve one area of the system but worsen other areas. Sustainability is about management options that improve the system as a whole.

This is one of few LCA studies covering the whole UWS. Main focus regarding environmental performance was given to water withdrawal and energy consumption.

Evaluated scenarios included different degrees of upgrading existing technology, centralize vs on-site treatment and demand management. The aim of this study was perform a holistic assessment of the system in order to show which aspects of the business are responsible for the largest environmental burdens and to compare alternative future scenarios. This was part of reviewing the Local Water plan 21.

Authors concluded that implementing desalination plants for drinking water treatment would significantly increase greenhouse emissions while achieving a fairly small increase of water supply, upgrading existing WWTPs to perform tertiary treatment would decrease the potential for eutrophication of coastal waters but it will worsen all other indicators of environmental performance. Authors conclude that scenarios that integrate several management options than just upgrading existing technology are the ones that actually improve the overall environmental performance.

3 Materials and Methods

3.1 Study site

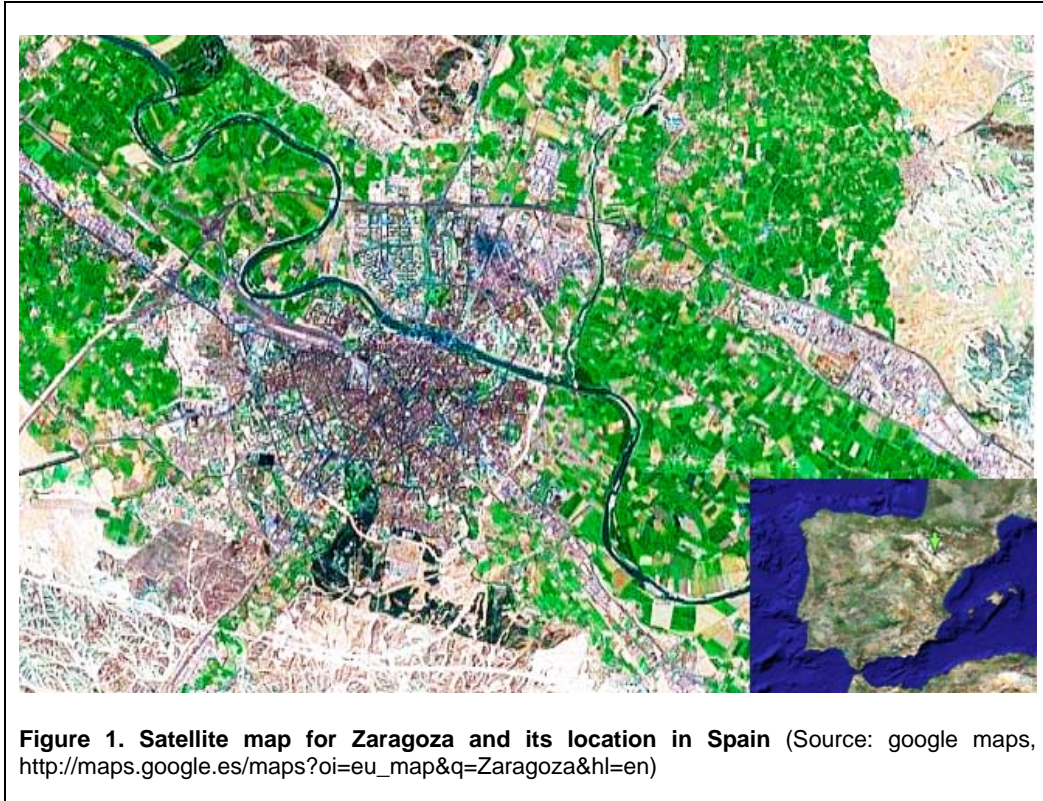

Zaragoza is the capital city of the autonomous region of Aragon in Spain, and is located on the Ebro River Catchment, and its tributaries the Huerva and Gállego. The city is 199 metres above sea level and is near the centre of the region. The population of the city is around 700.000, ranking fifth in Spain. Climatic conditions of Zaragoza are a transition between Mediterranean and Continental climate with an average temperature of 15°C. The Ebro River Valley at Zaragoza is a semiarid region with an average annual precipitation of 367 mm concentrated in 67 days, ranking as the driest inland region in Europe. The Ebro River drains a triangular basin with an area of 85.820 Km², between the Pyrenees and the Iberian Mountains, with the Cantabrian Mountains as northern border. The Ebro is the largest river in Spain with a course 928 km long and total annual discharge of 19,000 million m³. The main use of water resources along the Ebro River Catchment is agricultural irrigation, followed by hydropower generation, urban supply and Industrial activities. The river is characterized by a wide range of seasonal variation of the river discharge. Therefore, since the 1930's, 138 reservoirs have been constructed in the river basin, with a total storage capacity of 6,837 Hm³ (CHE, 2007)

The Municipality of Zaragoza is responsible for water planning and management in the city. They own and operate facilities for drinking water supply, sewers and wastewater treatment plants. During the last decade Zaragoza has carried out several important projects concerning water management. In 1993 a WWTP providing tertiary treatment was built. At the same time sewerage system began expanding and nowadays almost all industrial discharges -with two special exceptions that will be further discussed in this report- are connected to sewers.

In 1997 the city started a project called "Zaragoza water saving city", consisting of education programs to encourage rational water use at households and industries by means of water saving devices and improving consumption habits. The municipality committed within this project to a rational use of water for landscaping. In 2005 this project managed to considerably reduce water demand and it was selected by Habitat UN as one of the 100 successful projects concerning urban sustainability worldwide. Currently municipality is using tariffs for water supply and WWT services as an instrument to punish excessive consumption as well as to reward saving. In the year 2000 both national and regional government approved a project aimed to shift the tap water source from the Ebro to the Aragon River regulated in "Yesa" reservoir in the Pyrenees, where water quality is more suitable for human consumption than in the Ebro River.

In 2002 municipality initiated a seven years project aimed to improve water supply for Zaragoza. This project consists on (1) upgrading the DWTP, (2) replacing, upgrading or taking out of work existing tanks and pumping stations and (3) replacing a considerable percentage of the pipeline network. Total investment for this project is around 82 million euro. As result of all these efforts Zaragoza's water withdrawal has significantly decreased.

3.2 General Approach

A systems approach is used here to analyze the Urban Water System of Zaragoza by means of Life Cycle Analysis (LCA). The procedure usually comprises four steps: (1) goal and system definition, (2) life cycle inventory (3) impact assessment and (4)

interpretation (U.S EPA, 2006; Ayers and Ayers, 2002). For the present work the step 3 was not carried out and interpretation is made from the life cycle inventory.

3.2.1 Developing flow diagram

First step to define system boundaries is developing a flow diagram showing the processes to be evaluated. In the present work the aim is to analyze all the major processes for the urban water system: water withdrawal, water treatment and distribution, water use, wastewater transportation and wastewater treatment. Along these processes a water balance is made and major flows and stocks of chemical products, nutrients and heavy metals are considered. The direct and indirect consumptions of energy (transportation of chemical products and sludge) are also considered, as well as direct (sewage sludge treatment and disposal) and indirect atmospheric emissions (derived from energy consumption).

3.2.2 Time horizon

An assessment of sustainability should ideally extend over a time horizon of several decades (Lundin and Morrison, 2002). However due to time and data constraints, the time period considered here is six years, which considers major investments on improving the technical performance of the water system.

3.2.3 Data collection

Data collection for this M Sc research lasted from November the 8th up to December the 29th. As starting point staff from the Local Agenda 21 Office provided some reports concerning water management in Zaragoza as well as specific features of the Urban Water System and its evolution during the last decade.

Most time was devoted to carefully review those reports in order to fully understand the sustainability issues that have been already identified by the municipality as well as other issues, probably neglected so far and which might be interesting for the SWITCH project.

Recent data necessary to perform mass and energy balances are partially available in different electronic formats such as notepad, pdf, word, excel, etc. Historical data are

mostly available only in hard copies. When specific information concerning Zaragoza system was not available, the extrapolation of general information has been considered.

3.2.4 Data analysis

A water balance was performed from the information available at Zaragoza municipality (figure 2, and annexes). Mass balances were performed for BOD₅, COD, TN, TP and Heavy metals at the WWTPs. As shown in Annex 1 there are several processes for which there are no data available at Zaragoza municipality. For such processes, assumptions and extrapolations from literature values were made. A description of these assumptions and calculations is provided next.

3.2.4.1 Storm water

No data concerning storm water quality exits in Zaragoza (which is understandable for a semiarid region) therefore the possible effects of storm water upon WWT performance are completely unknown. The possible effect of storm water upon the Ebro River is here extrapolated from the chemical characteristics of sewage and the possible overflows, which have not been actually measured, but have been estimated as follows (for raw data and calculations for storm water refer to annexe 10):

$$\text{Estimated storm water} = \text{Precipitation} * \text{impervious area}$$

$$\text{Overflows} = \text{Estimated storm water} + \text{Expected WWTPs inflow} - \text{Actual inflow to WWTPs}$$

Daily precipitation data for Zaragoza was provided by the Local Agenda 21 Office at Zaragoza municipality. There were no data concerning evaporation, extrapolation was made from Marti (2000).

3.2.4.2 Energy consumption and CO₂ emissions from transportation

Environmental impacts derived from transporting both chemical products and sludge were calculated as energy consumption and CO₂ emissions to the atmosphere. Factors from Thonstad (2005) were used (for raw data and calculations refer to annex 9)

3.2.4.3 CO₂ Emissions from electricity consumption

Raw data concerning energy consumption of the DWTP and the WWTPs were provided by the Local Agenda 21 Office at Zaragoza. The derived CO₂ emissions were calculated regarding the electric energy sources in Spain provided by Ministerio de Industria, Turismo y Comercio de España (2007) referred in figure 9. Emission factors from European Commission (1995) were used (for raw data and calculations refer to annex 8).

3.2.4.4 CO₂ production from sludge

Wastewater sludge emits CO₂ as a function of the OM concentration. Raw data regarding wastewater sludge production at the WWTPs were provided by the Local Agenda 21 Office at Zaragoza municipality. COD content in the sludge was calculated from the mass balance between inflow and outflow load at each facility. Multiplication factors from Levlin (2005) were used to calculate TOC content and CO₂:

$$\text{TOC} = 40\% \text{ of COD}$$

$$\text{CO}_2 = 3.66 * \text{TOC}$$

3.2.5 Scenario analysis

Based on the collected data, an exercise for Scenario Analysis is presented following the methodology suggested by Assimacopoulos (2007) in which the main drivers for change and sustainability are identified by means of a problem tree analysis. Drivers are qualitatively discriminated under the criteria of importance and uncertainty. Possible scenarios resulting from the combination of drivers considered as more important and more uncertain are set. Finally strategies to cope with such scenarios are suggested. The aim of the strategies is to adapt the system to reach a sustainability vision.

4 Results

4.1 Data availability and information gaps

In order to improve processes it is necessary to get a set of data that describes such processes as best as possible. Therefore, one of the goals of this research was to identify current information gaps that need to be filled in order for Zaragoza municipality and other stakeholders to get a better picture of the weaknesses and strengths of the urban water system, which will significantly contribute to set up priorities. The following are the information gaps identified to be important in this research:

1. Groundwater recharge
2. Parasitic water to the sewers
3. Storm water quantity and quality
4. Industrial vs Domestic contribution to pollution loads to the sewage
5. Actual leakage in the distribution network
6. Distribution and Sewer network modeling

Both distribution and sewer network are fully mapped and implemented in a GIS, which is of high potential for covering information gaps and improve water management.

Annex 1 lists the information necessary for LCA and its availability at Zaragoza municipality. The frequency of measurements or samplings, the type of data and the aggregation level are also described. Most data are available from 2000, previous data exists as hardcopies deposited in archives which were not assessed due to time limitation for this M Sc project. Most data gathered were measured with some exceptions were estimations were made from printed reports. Since no modeling has been implemented by the Municipality to any of the UWS process there are no modeled data.

4.2 General features of Zaragoza UWS

Figure 2 shows the flow diagram for Zaragoza UWS, including a water balance and material inputs (chemical products) and outputs (sludge). The general features of this water system are summarized in this figure where 8 levels are recognized: (1) water inputs which includes storm water, tap water source, agriculture irrigation and groundwater; (2) drinking water treatment process; (3) distribution system; (4) Water

consumption and use, which includes households, public facilities, landscaping, industry connected to the sewer system and industry using exclusively groundwater and not connected to the sewer system; (5) combined sewer system (6) WWTP which includes two public facilities and two private ones (7) receiving environment and (8) chemical products used for both DWT and WWT. Every level will be explained in more detail next and figure 2 will remain as recurrent reference along the text.

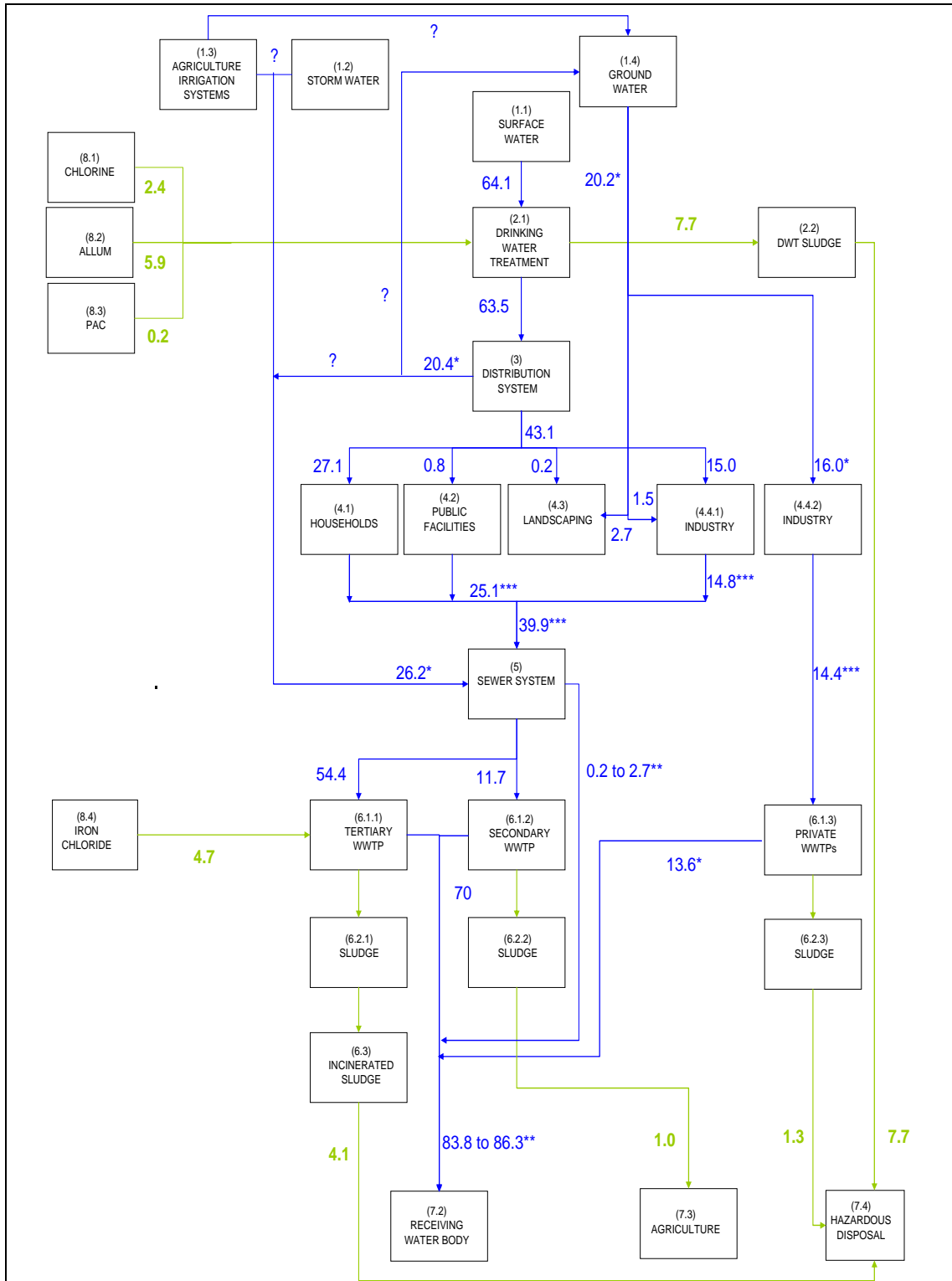

Figure 2. Flow Diagram for Zaragoza UWS. Lines and numbers in blue stand for water flows (units are million m³ per year). Chemical products as well as sludge flows are represented by lines and numbers in green (units are thousand tons per year). Data used for this diagram are from the year 2006.

* Values that have not been measured but estimated
 ** Storm water overflows were estimated for the period 2001 – 2006 and are completely different between years. Therefore an average value is not given, but rather a range.
 *** 90% of water use is assumed to go to the wastewater system
 ? Indicates balances that could not be completed due to information gaps
 Values that have been actually measured are not given any mark in this figure

4.2.1 Water inputs

4.2.1.1 Tap water source

Tap water source which is the Ebro river diverted 110 km upstream from Zaragoza by “Canal Imperial de Aragon”. Ebro river discharge strongly fluctuates on a seasonal basis, being as high as $500 \text{ m}^3 \text{ s}^{-1}$ in March and as low as $30 \text{ m}^3 \text{ s}^{-1}$ in August. Quantity is sufficient to supply the city all over the year because the river is largely regulated by dams up stream, otherwise the city would suffer from shortages during summer time. For the year 2006 total water withdrawal for Zaragoza was 64.1 million m^3 without including ground water (see figure 3).

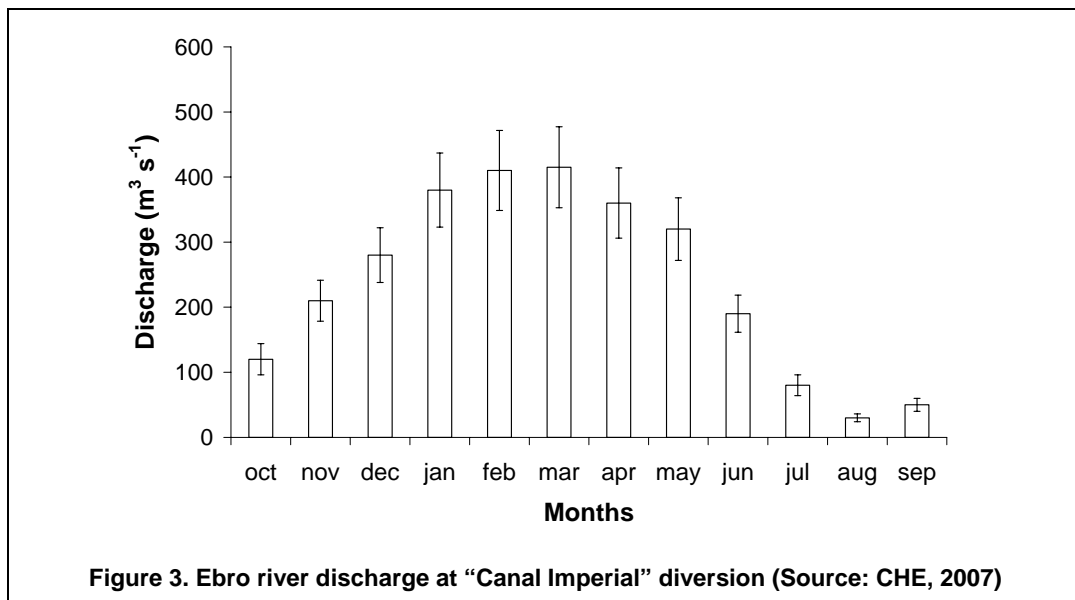

Raw water quality in Zaragoza is very much affected by the seasonal fluctuations of the Ebro River. Conductivity and hardness increase in summer time due to the strong reduction in water discharge, making water eventually unsuitable for drinking purposes. During spring and fall high discharges reduce conductivity but suspended solids and organic matter –mostly humic substances exerting high chlorine demands– significantly increase. More suitable water quality is achieved only during winter time. High chlorine demands eventually lead to hyper-chlorination and to high concentrations of oxidation and disinfection by-products. Several parameters of tap water quality often exceed standard regulations (Local Agenda 21 Office of Zaragoza, 2002). Due to these characteristics of raw water quality, drinking water

treatment in Zaragoza requires large amounts of chemical reagents implying not just a high cost of water treatment, but also a risk to public health due to DBPs.

Shifting to a different raw water source and thereby reducing treatment cost and improving water quality is a strong need for the city. From 2008 the city will receive water from the Pyrenees, specifically from the Yesa reservoir which regulates the Aragon River and is also used for irrigation and hydropower production. A significant improvement of tap water quality for Zaragoza is expected from this new source. This will be discussed further on in the Scenario Analysis section.

4.2.1.2 Storm water

Zaragoza is located in a semiarid region with an average precipitation of 270 mm per year, which is concentrated within 70 to 80 days (see figure 4a, showing 2006 daily based hydrograph as example). Precipitation per day in Zaragoza would rarely exceed 20 mm and dry and wet periods are not quite distinct. However, highest maximums and highest averages are reached in May and in September, but rarely exceeding 50 mm per month. Lowest averages and lowest minimums are usually reached in August and in December (see figure 4b).

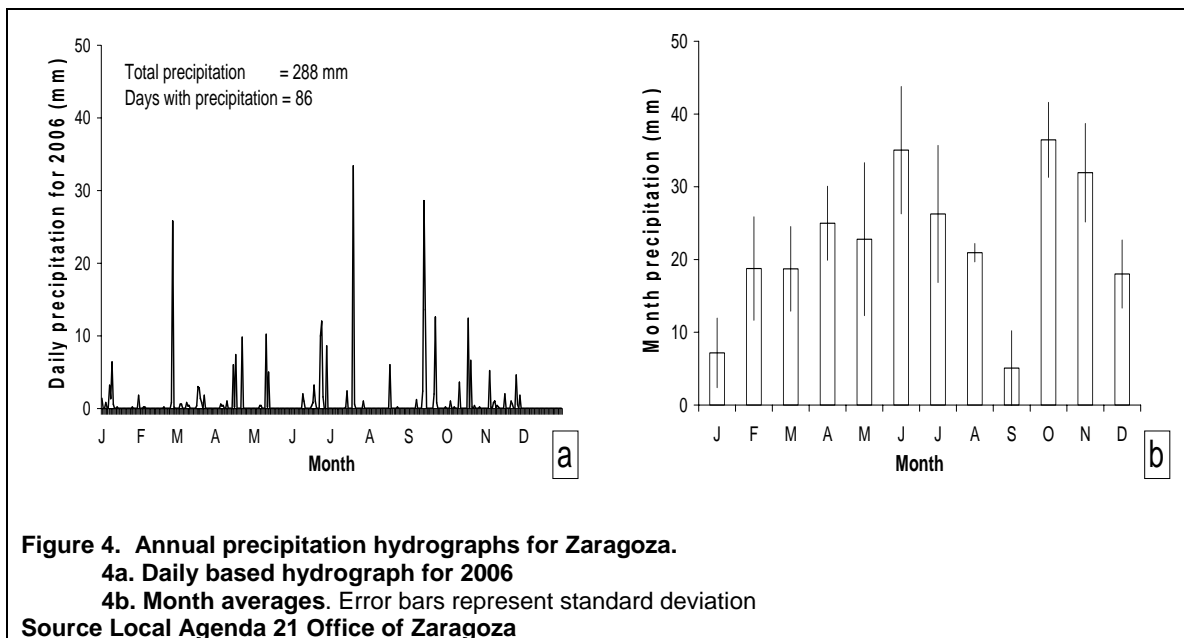

Due to these hydrologic conditions storm water is not considered an issue by the Municipality. Nevertheless eventual overflows of storm water are discharged directly in the Ebro River without any treatment. Therefore Municipality is building two storm

water tanks to prevent the consequent pollution of the river. They are also considering about using storm water for cleaning public facilities or for landscaping.

According to the municipality staff the sewer system has got serious dimensional limitations. Therefore, even under the consideration that Zaragoza is a semiarid region, storm water might saturate the system and overflow to the Ebro River under strong rain events

4.2.1.3 Agriculture irrigation systems

The Ebro Valley at Aragon is the driest inland region of Europe. In fact most of the area around Zaragoza is naturally either bare or covered with desert-like vegetation. Water deficits are high due to low precipitation (less than 300 mm) and high evapotranspiration (more than 800 mm). Most of the soils of the region are Aridisols, and show similarities to those of North African deserts. However agriculture is an important activity along the Ebro catchment and the most relevant use of water resources in the catchment is agricultural irrigation. In Zaragoza province, including the surroundings of Zaragoza city, the irrigated area is nearly 177,000 ha (see figure 5).



Figure 5. Irrigation in Zaragoza province. This satellite picture shows the desert surroundings of Zaragoza city. All the green areas are irrigated agricultural lands (Source: google maps, http://maps.google.es/maps?oi=eu_map&q=Zaragoza&hl=en)

Irrigation water is considered here as an input for Zaragoza UWS for two reasons: 1) excess water from irrigation is 100% responsible for recharging the city's aquifer and 2) some irrigation systems in the borders of urban area become parasitic water to the sewer system and end up in the WWTP. Both total contributions to the aquifer as well as to the sewer system are currently unknown.

4.2.1.4 Ground water

In Zaragoza groundwater is not given any price and the water table is relatively shallow (5m in average). It is being extracted for industrial activities and for landscaping but it is not included by Zaragoza's municipality in its account for total water withdrawal because it does not enter the distribution network. The institution responsible for authorizing groundwater extraction is not the Municipality but the CHE.

Figure 2 shows groundwater withdrawal and its use in Zaragoza. The major consumer is Industry that is not connected to sewer system, corresponding to two paper mills owning private WWTPs and discharging into the Gallego and the Ebro River. If groundwater extraction is added to the calculation of water withdrawal, the actual consumption of Zaragoza UWS is 84 million $\text{m}^3 \text{ year}^{-1}$ of which 23% is groundwater.

As stated previously, ground water in Zaragoza is not recharged by a natural water cycle. There is no recharge from the Ebro River either. All groundwater in Zaragoza come from agricultural irrigation in the surrounding area. Current rates are estimated in $10,000 \text{ m}^3 \text{ ha}^{-1}$ but the total irrigation area that is contributing to recharging the aquifer of the city is unknown and therefore so it is the total recharge (Ebroagua working group, personal communication).

4.2.2 Drinking water treatment

Water from the Canal Imperial is treated in a plant with an installed capacity of $6 \text{ m}^3 \text{ s}^{-1}$. Conventional treatment is applied, comprising: pre-chlorination, flocculation, sedimentation, rapid sand filtration and disinfection with chlorine. The consumption of chemical products for DWT is summarized in figure 2 and also it will be explained in more detail further on.

As part of the policy of reducing water consumption adopted by the municipality the DWTP has been upgraded to dewater the sludge. Up to the year 2002 sludge with

nearly 90% water content was directly discharged into the Huerva River. From 2003 approximately 5 million m³ of water per year (7.7% of total water withdrawal) are being recovered from sludge and recycled into the DWT process.

4.2.3 Distribution network

By the year 2002 Zaragoza water distribution network was rather old. Most facilities ranged between 30 and 90 years of being built. Pipelines and reservoirs suffered important leakages and required to be either upgraded or replaced. Uncovered reservoirs were common, which is not convenient for stability of water quality.

Table 1 shows the current situation of distribution network reservoirs. From Casablanca reservoir at the DWTP (currently under upgrading) water is distributed to the whole system. It can be seen that most of the system works by gravity and only one reservoir is a pumping station. Therefore energy consumption by distribution network is very low as compared to other processes of the UWS.

Table 1. Zaragoza's Primary Distribution System. Current situation (Source Infrastructure Department, Urban Water Cycle Office of Zaragoza, 2006)

Tank name	Operation mode	Capacity (m ³)	Age (years)	Stage before plan enforcement	Current Stage
Casablanca	Gravity	180.000	90	Bad	Upgrading
Pignatelli		82.000	125	Bad	Out of work
Valdespartera		50.000	30	Excellent	Same
Canteras		14.400	70	Suitable	Upgraded
Los Leones		4.000	35	Suitable	Upgraded
Academia		15.000	35	Suitable	Upgraded
Villamayor		150	25	Good	Same
Peñaflor (alto)		200	25	Good	Same
Garrapinillos		100	25	Good	Same
Villarrapa		560	25	Good	Same
Valdefierro	Pumping	-	-	Bad	Out of work
D.B Oliver		-	-	Bad	Out of work
Garrapinillos		-	-	Good	Same

Pipelines are being actively replaced in order to reduce leakages, current replacement rate is about 33 km a year, requiring approximately 53 million euro, being therefore the highest investment issue after the construction of the new pipeline bringing water from the Yesa dam.

One important limitation to properly assess the environmental performance of Zaragoza UWS is the lack of information concerning the flows through the distribution

network. There are online meters at most facilities, but there is no data base. Therefore it is not possible to differentiate actual leakages at the distribution network from other factors contributing to unaccounted water, which has been reducing during the last decade, but still continues to be considerably high.

In 2002, starting point of the water supply improvement plan, unaccounted water was as high as 34 million m³ a year, nearly 45% of total withdrawal. Municipality estimated by that time approximately 17 million m³ to be actual leakage in the distribution system, but this is just a rough estimation. In 2006 unaccounted water was around 32% of total withdrawal (see table 2). The goal is to reduce it below 15%. The main demonstration activity for Zaragoza within SWITCH project is to carry out a complete water balance for one sector of the city in order to improve the current knowledge about water consumption and leakage in order to reduce the percentage of unaccounted water.

4.2.4 Water use

As it can be seen in figure 2, domestic use accounts for approximately the 62% of metered consumption. Industrial activities represent the 36% and public facilities plus landscaping consume only 2%.

Data concerning water withdrawal and water consumption from 1997 –when campaigns for rationalizing water use at households and industries started– to 2006 are shown in table 2. Along this period water withdrawal has been reduced by 20 million m³ year⁻¹ due to both consumption reduction and infrastructure upgrading.

Along the last decade domestic consumption has gone down from 140 to 110 l person⁻¹ day⁻¹, leading to 6 million m³ year⁻¹ less withdrawal; even with population increasing with around 50 thousand people during the same period. Thus infrastructure upgrading accounts for 14 million m³ year⁻¹ reduction.

Table 2. Evolution of water withdrawal and consumption in Zaragoza

Year	Withdrawal (million m ³ per year)	Population (thousand inh)	Average consumption (l person ⁻¹ day ⁻¹)	Metered consumption (million m ³ /year)	Unaccounted tap water (%)
1997	84.7	601.6	139.8	39.9	45.6
1998	80.2	606.0	132.2	41.5	43.0
1999	80.4	607.3	132.2	41.2	43.2
2000	79.3	608.1	129.4	41.8	41.2
2001	79.7	613.4	128.8	42.5	39.0
2002	74.5	622.6	124.6	42.7	39.9
2003	71.7	628.4	122.4	44.1	38.2
2004	70.8	641.6	123.3	44.3	37.4
2005	68.2	650.6	118.0	44.6	35.0
2006	64.1	657.0	110.0	43.1	32.8

In spite of the important contribution of domestic water savings to the overall reduction of Zaragoza water withdrawal, municipality assumes that households are the major contributor to tap water losses since all over the city there are about 7000 to 7500 drinking water storage tanks installed between 30 to 40 years ago at the basement of buildings with the aim to assure continuous availability of water. At that time shortages were relatively common. Nowadays Zaragoza municipality considers such facilities not just unnecessary -since shortages have become very unusual- but also a source of problems since these tanks are poorly or even not maintained at all. There are three sustainability issues concerning these tanks:

- *Energy losses.* By definition these facilities break the pressure existing in the pipeline –which would be enough otherwise to bring water up to the top of the building– making necessary for the building to consume electricity in order to pump water up.
- *Water losses.* Municipality considers these tanks as the main source for water losses since poor maintenance may leave to continuous overflows that are discharged into the sewers (figure 5), mostly during low demand time (night time and holydays). Such losses become part of unaccounted water since meters are located at the outflow of the tanks (figure 5).
- *Public health.* Legionella, Mycobacterium, enteric Amoebas as well as other opportunistic pathogens and nuisance organisms, some of these largely resistant to chlorine, may multiply inside these tanks when residence time increases (WHO, 2004).

Due to these problems Zaragoza Municipality wants the tanks to be taken out of work, which they cannot do directly since those are private facilities. Municipality is considering to carry out campaigns to inform people about the disadvantages of such

facilities, but nothing has been done yet. The Local Agenda 21 Office also suggested an assessment of water losses and energy consumption for these tanks as part of demonstration activities for Zaragoza within the SWITCH framework. Figure 6 shows a scheme of the typical breaking pressure tank as described by municipality staff.

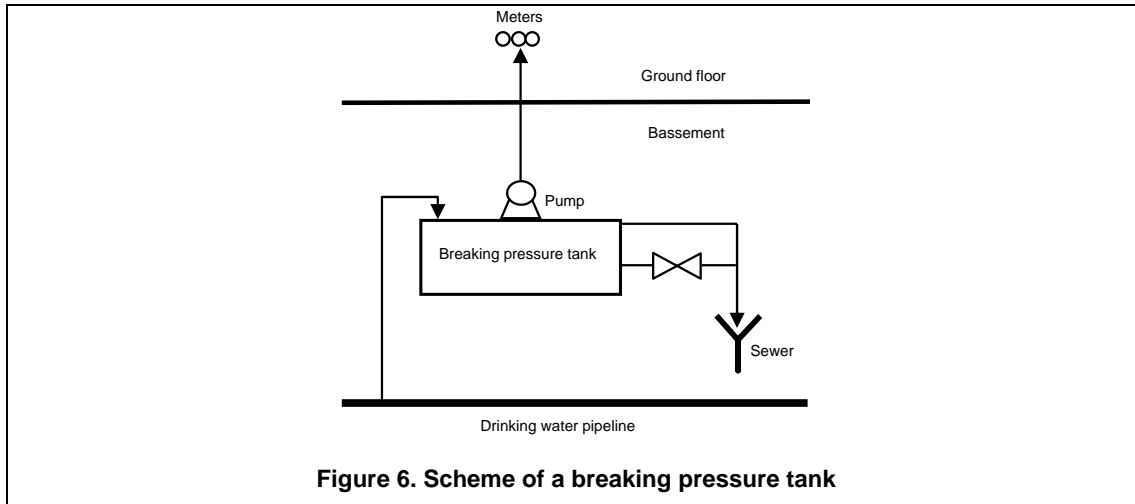

4.2.5 Sewer system

Zaragoza has got a combined sewer system to which nearly all Industries and neighborhoods are nowadays connected. As previously described, some excess of irrigation water may also reach the sewer system. Nearly all industrial activities are currently taking place in areas surrounding the city, so called "Industrial Polygons". Industrial discharges are regulated by a local law since 1986. There are 23 physico-chemical parameters that industrial waste waters must meet to be discharged into municipal sewers. Local Agenda 21 Office asks each industry for a discharge statement where all substances and processes involved in the industrial activity must be described. Industries should also implement management options intended to reduce WW pollution. Substances classified as harmful or toxic are not to be discharged into municipal sewers. Agenda 21 Office carries out inspection visits in order to confirm the information provided by the industry. Industrial discharge statements are classified as shown in table 3.

Table 3. Classification of industrial discharges in Zaragoza in 2005

Class	Definition	% of Industrial activities falling in each category in 2005
0	Similar to domestic WW. No statement required	25
1	Discharge < 15 m ³ day ⁻¹ . No toxic substances	65
2	Discharge > 15 m ³ day ⁻¹ and < 50 m ³ day ⁻¹ . No toxic Discharge < 15 m ³ day ⁻¹ possible content of toxic substances	5
3	> 50 m ³ day ⁻¹	5

Information concerning each industrial discharge statement is introduced into a data base. Included aspects are:

- Discharge location
- Industrial activity
- Both potential and actual pollutants emitted to the environment
- Toxic substances used along the industrial process
- Water consumption
- WW quality
- WWT or processes aimed to reduce WW pollution
- Legal information (licences, etc)

Zaragoza sewer infrastructure is fully mapped in a GIS, but it has not been yet modelled, therefore there are no data concerning flows or substances transport and transformation.

4.2.6 Wastewater treatment

Zaragoza has got two public WWTP. General features for the two plants are provided in table 4. The average inflow for “La Almozara” is 12 million m³ year⁻¹ for “La Cartuja” is 59 million m³ year⁻¹. In addition to those public treatment plants there are also two private ones treating industrial sewage from two paper mills which do not use tap water but extract groundwater. Since these two companies own WWTPs they are not connected to Zaragoza sewer system, but discharge into the Gallego and the Ebro River (see figure 2). The authority in charge of controlling such discharges is not the Local Agenda 21 Office but the CHE. These two WWTPs provide the same sewage and sludge treatment than “Almozara” and together they treat even more water, around 13.6 million m³ year⁻¹ (see figure 2). Therefore they are also considered for all analyses in this report and they will be referred to as “Paper mills”.

Table 4. Zaragoza public WWTPs

WWTP	Cartuja	Almozara
Parameter		
Sewage Origin	Industrial and domestic	Industrial and domestic
Average flow at design ($\text{m}^3 \text{s}^{-1}$)	3.00	0.40
Average actual flow in 2006 ($\text{m}^3 \text{s}^{-1}$)	1.72	0.37
Water treatment	Primary sedimentation, Biological treatment by activated sludge and secondary decantation	Primary decantation, Biological treatment by activated sludge and secondary decantation, Phosphorus removal with Iron Chloride
Sludge treatment	Primary and secondary digestion plus dehydration by filter press	Centrifuge dehydration followed by incineration

As it can be seen in table 4 “Almozara” is working near its actual capacity whereas “Cartuja” seems to be over dimensioned and is working at half of its actual capacity.

4.3 Environmental performance of Zaragoza UWS

4.3.1 Use of chemical products

Figure 7 shows the annual consumption of chemical products by Zaragoza UWS from 2000 for DWT and from 2001 for WWT. There is a steady trend over these years, but Chlorine and Alum shows a clear reduction for 2005 and 2006, from around 3000 to 2500 ton and from 8000 to 6000 ton respectively. PAC use for DWT started in 2003 and it has not been steady since then.

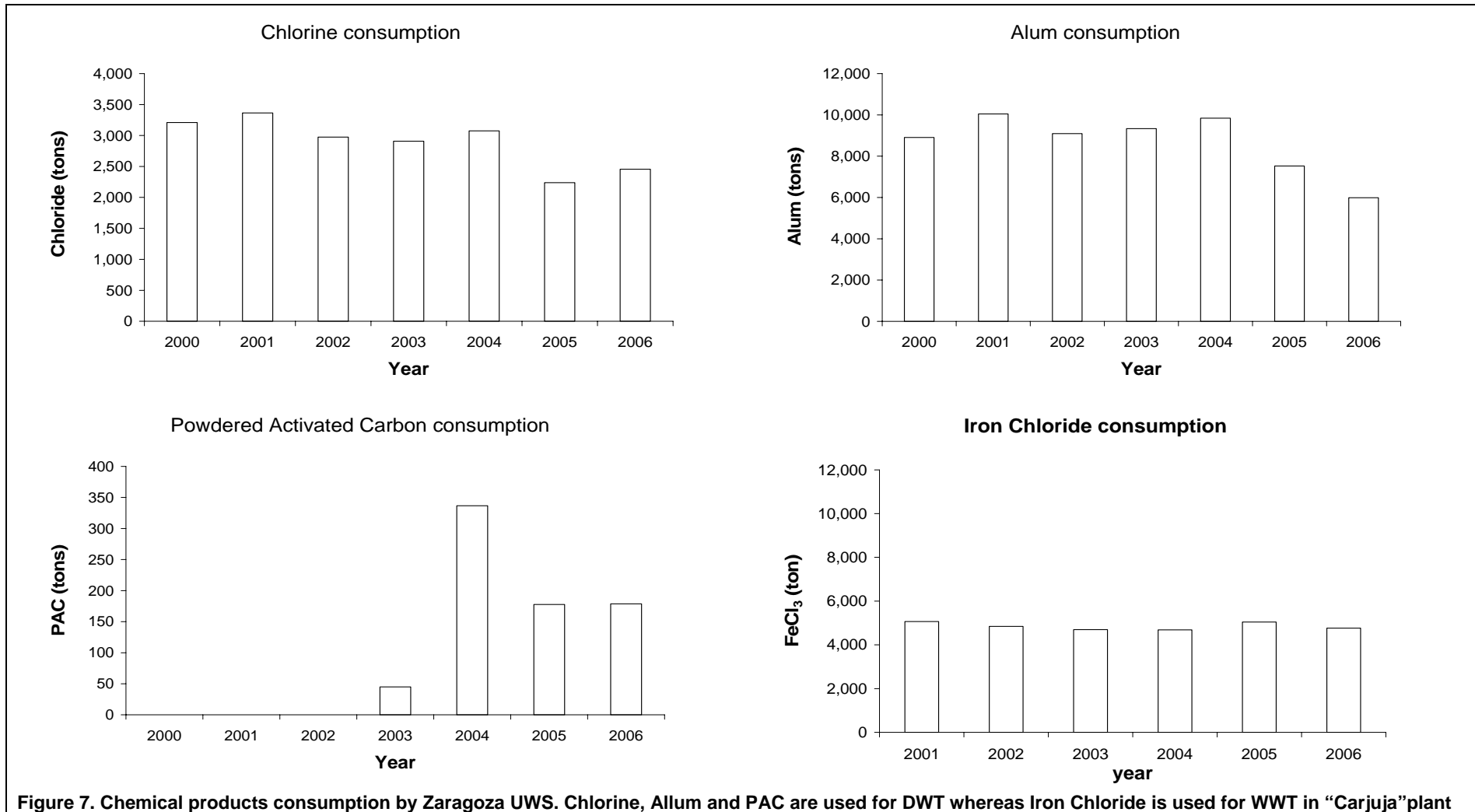

4.3.2 Energy consumption and Atmospheric emissions

Figure 8 shows the total energy consumption of Zaragoza UWS discriminated by process. Both direct as well as indirect energy consumption are included. Direct consumption is electric power required for operation. Indirect consumption is the one required for transportation of both sludge and chemical products. It can be seen that around 60% of total consumption is due to WWT process. The contribution of groundwater extraction to total energy consumption is negligible. Energy consumption per water cubic meter is around 0.35 Kwh for WWT, 0.12 Kwh for DWT and 0.02 Kwh for groundwater extraction. Sludge digestion at “Almozara” and “Paper mills” as well as heat recovery at “Cartuja” allow energy production by the UWS for about 4 Gwh every year, which represents 10% of total energy consumption by the UWS system. (see figure 8).

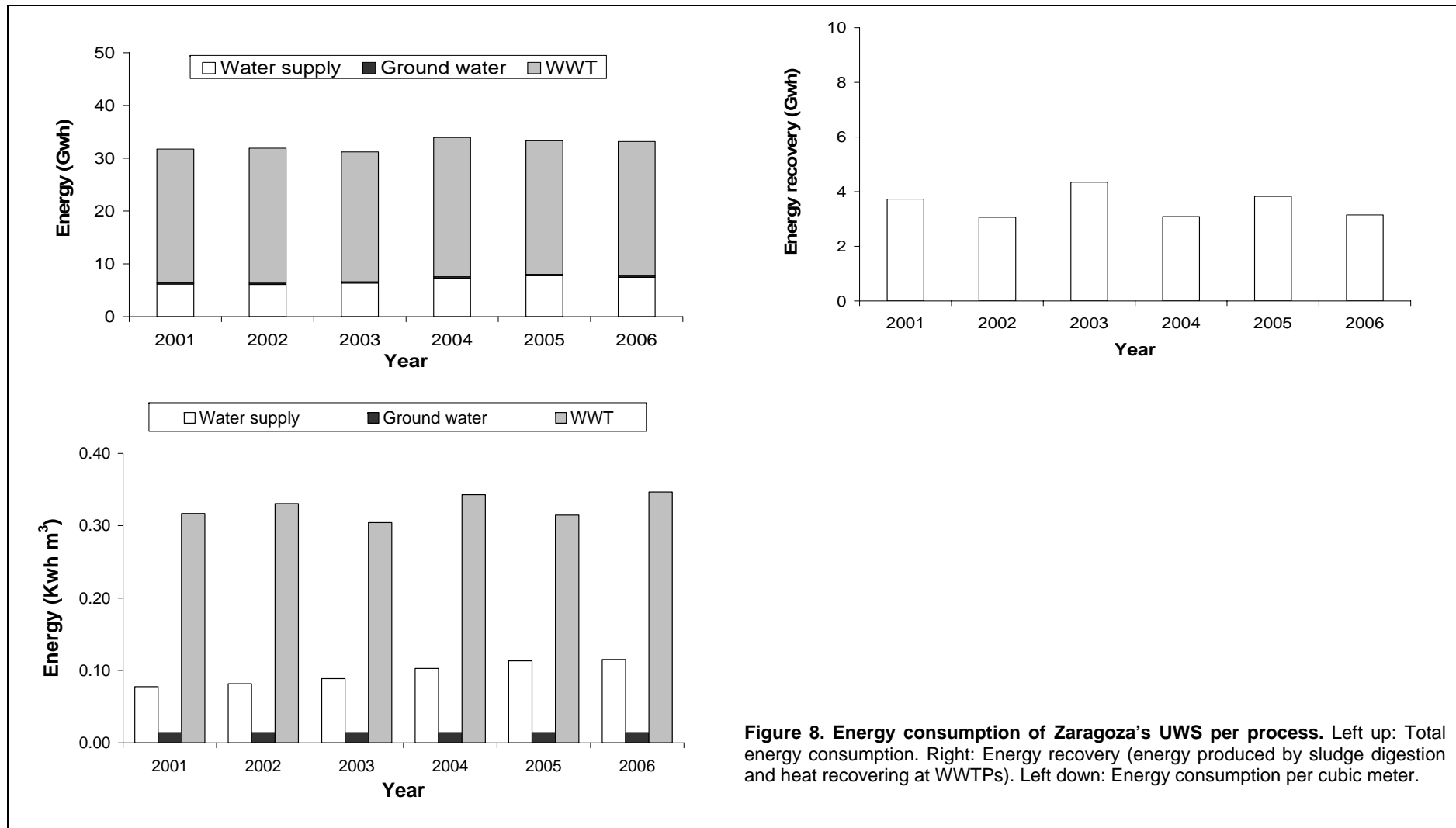

Figure 8. Energy consumption of Zaragoza's UWS per process. Left up: Total energy consumption. Right: Energy recovery (energy produced by sludge digestion and heat recovering at WWTPs). Left down: Energy consumption per cubic meter.

Figure 9 shows the current composition of electric sources in the market stock for Spain. It can be seen that nearly half of electric production is using fossil fuels (coal and combined cycles). From these percentages CO₂ emissions produced by electric energy consumption are 436 ton per Gwh.

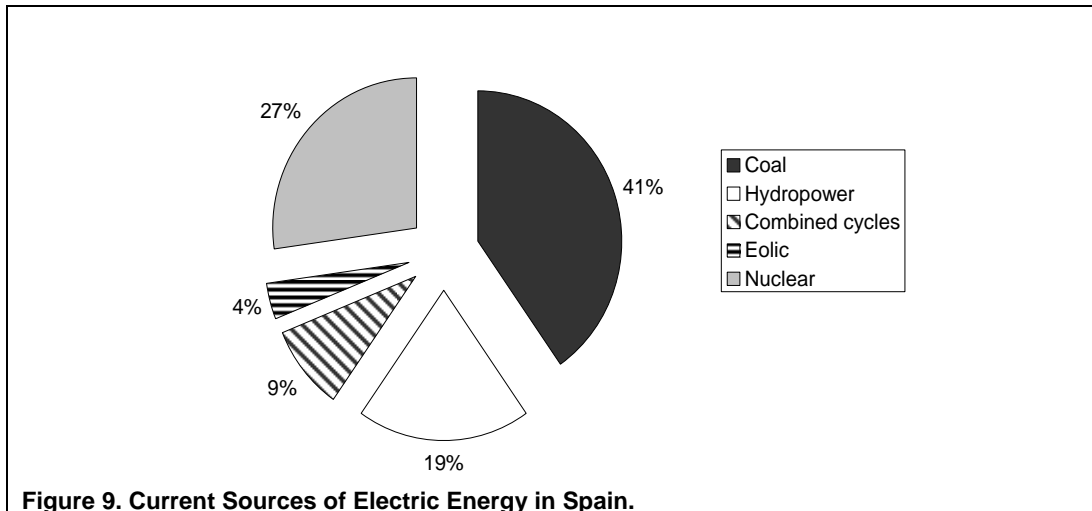
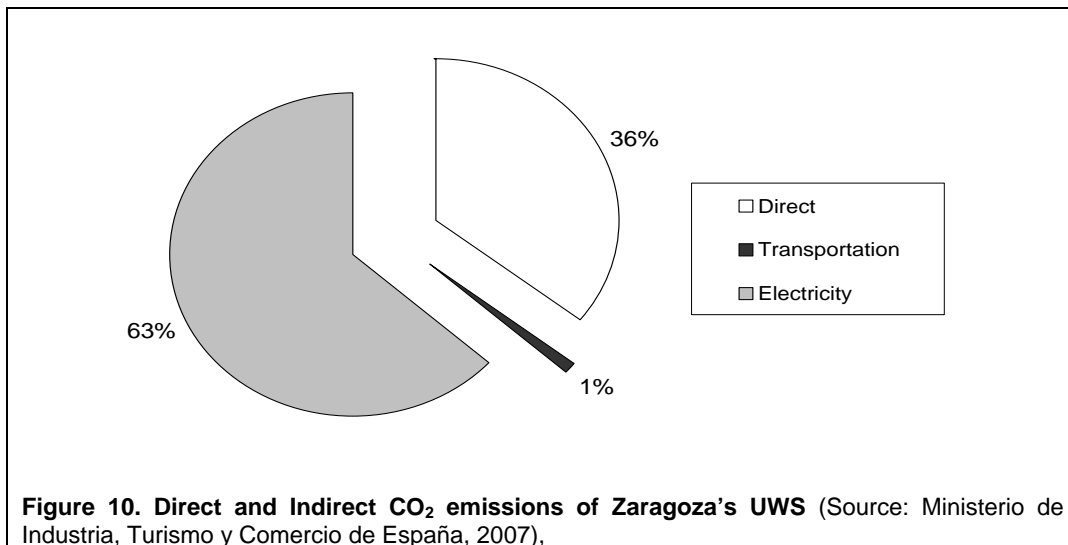
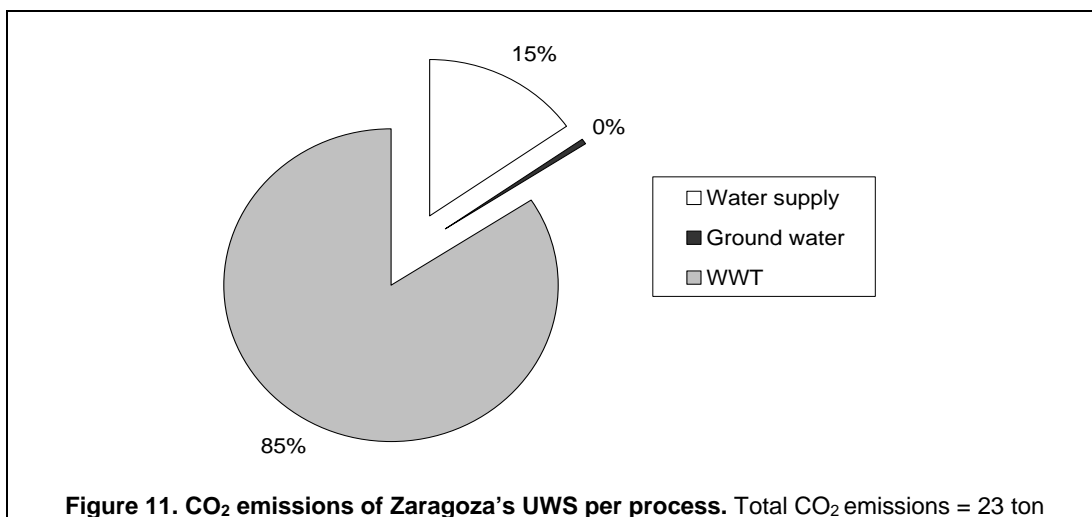

Figure 10 shows the main causes for atmospheric emissions derived from the operation of Zaragoza UWS. It is important to point out that water supply does not directly produce atmospheric emissions, but only indirectly from transportation of chemical products as well as from electricity use. Groundwater produces only indirect emissions from electricity use. All direct emissions from Zaragoza UWS are derived from WWT and correspond to: 1) sludge digestion; 2) further emissions from digested sludge degradation at landfill site (for paper mills); as well as 3) at agriculture fields (Almozara), and finally from sludge incineration (Cartuja). It is remarkable that only 36% are direct emissions whereas 63% are indirect emissions derived from electricity use, which results from the market composition described in figure 9.



As result of facts described by figures 8 to 10 WWT process is responsible for most atmospheric emissions (see figure 11).



4.3.3 Heavy metals

Figure 12 shows the heavy metal loads in Zaragoza sewage. Zinc (48%) and nickel (25%) are the most abundant.

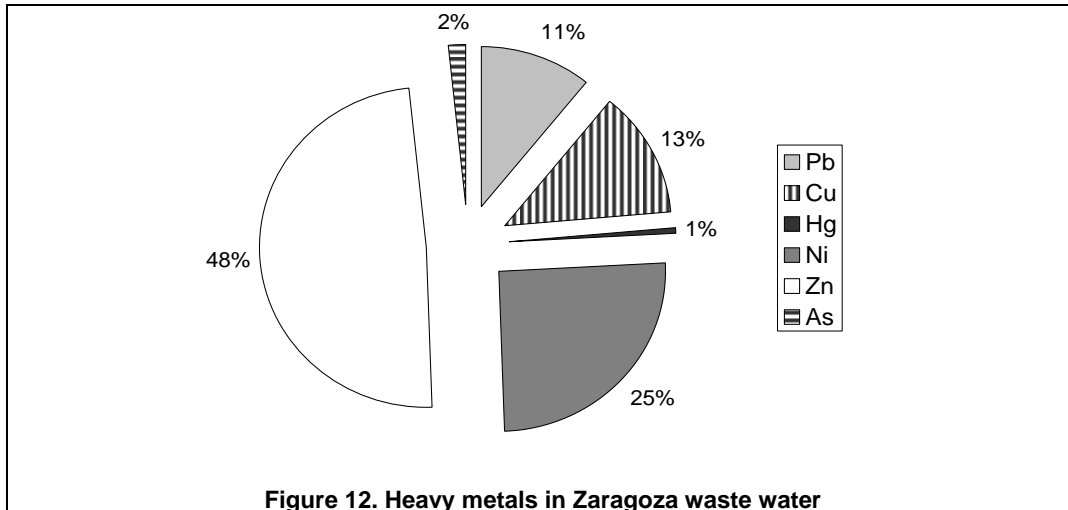

Figure 12. Heavy metals in Zaragoza waste water

Figure 13 shows the heavy metal annual loads from Zaragoza UWS to the environment. WWT technologies in Zaragoza are not designed to remove those, therefore it is not surprising that nearly 60% of total load every year is going to the Ebro river. Around 80% of the loads to the river are produced by “Cartuja” plant. “Almozara” produces loads that are quite similar to those from “Paper mills”. The impact of storm water is considerably low. Around 39% of heavy metals from sewage is disposed at landfill site and only a negligible fraction (around 1%) ends up in agriculture fields. Total annual loads to the river are around 23 ton year⁻¹ whereas total loads to landfills are around 13 ton year⁻¹. Loads to agriculture are 300 kg year⁻¹. Comparison between years shows only small differences with no clear tendency of heavy metal loads to either increase or decrease over time.

4.3.4 Organic matter

Biodegradable and non-biodegradable organic matter loads to the Ebro River expressed as BOD and COD respectively are shown in figure 14. BOD loads are around 1,000 ton year⁻¹ and COD loads are around 4,500 ton year⁻¹. Again around 80% loads come from “Cartuja” plant and loads from “Almozara” plant and from “Paper mills” are similar. Again the impacts from storm water are relatively low except for the year 2001 when it produced half of BOD load, increasing the city total two folds. COD load from storm water in the same year was not as high as BOD load, but it was comparable to those of “Almozara” and “Paper mills”.

4.3.5 Nutrients

Just as other pollution loads previously described annual loads of nitrogen and phosphorus do not show any tendency to either increase or decline over the years. Nitrogen loads to the Ebro River are around 3,000 ton year⁻¹. “Cartuja” plant accounts

for 75% of the total load to the river. Once again “Almozara” and “Paper mills” loads are quite comparable. Nearly 60% of nitrogen is being removed from the sewage by the WWT system and ends up in the sludge (no data concerning denitrification were available).

Since “Cartuja” plant is designed to remove phosphorus, the relative contribution of this facility to the TP loads to the Ebro River is relatively low as compared with all other pollution loads that have been already mentioned and it is even comparable to those loads from the other two facilities. As consequence of TP removal at “Cartuja” plant 65% of this nutrient is disposed in a landfill for hazardous materials (see figure 2) and only 3.5% is recycled to agriculture.

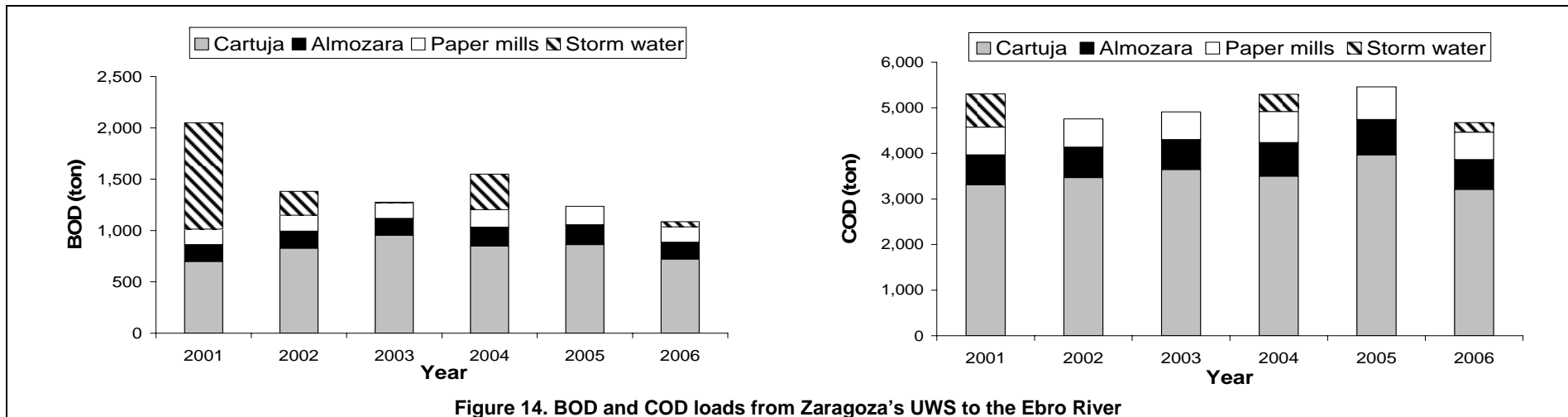
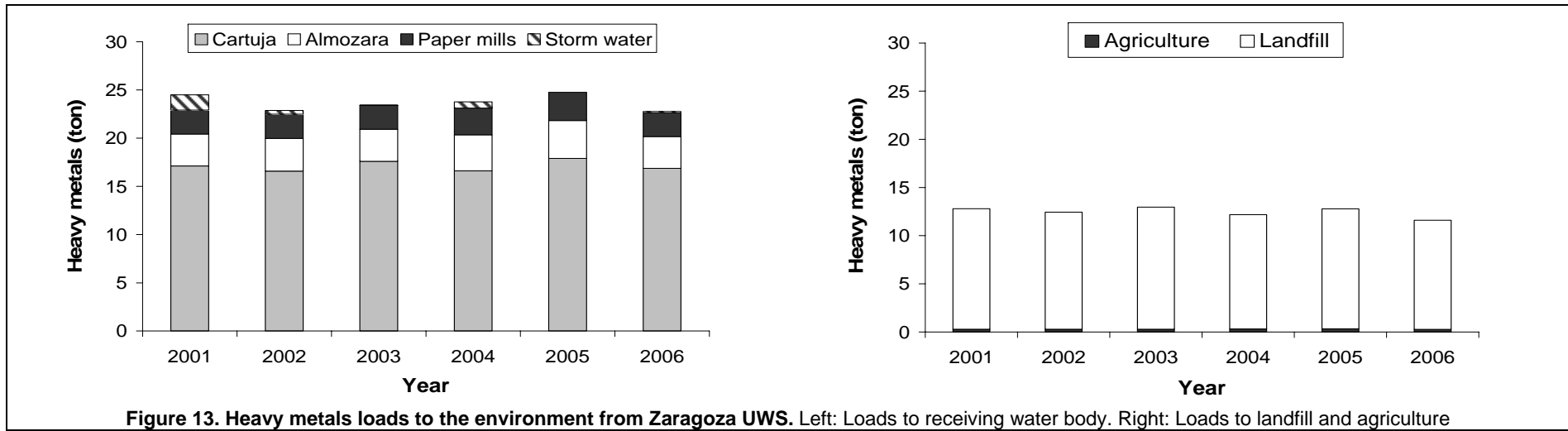

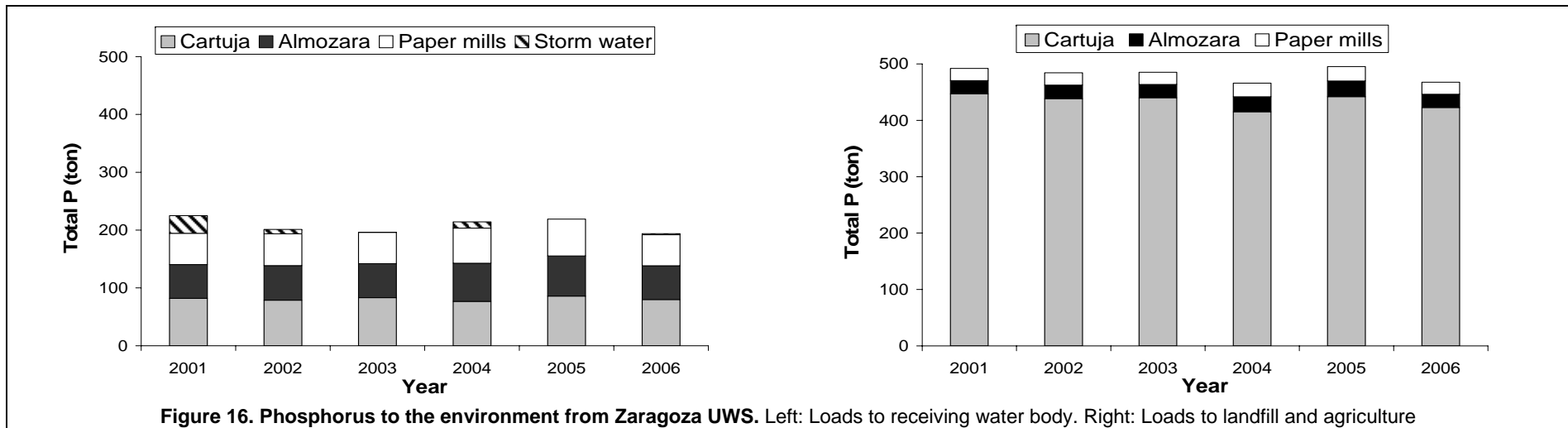
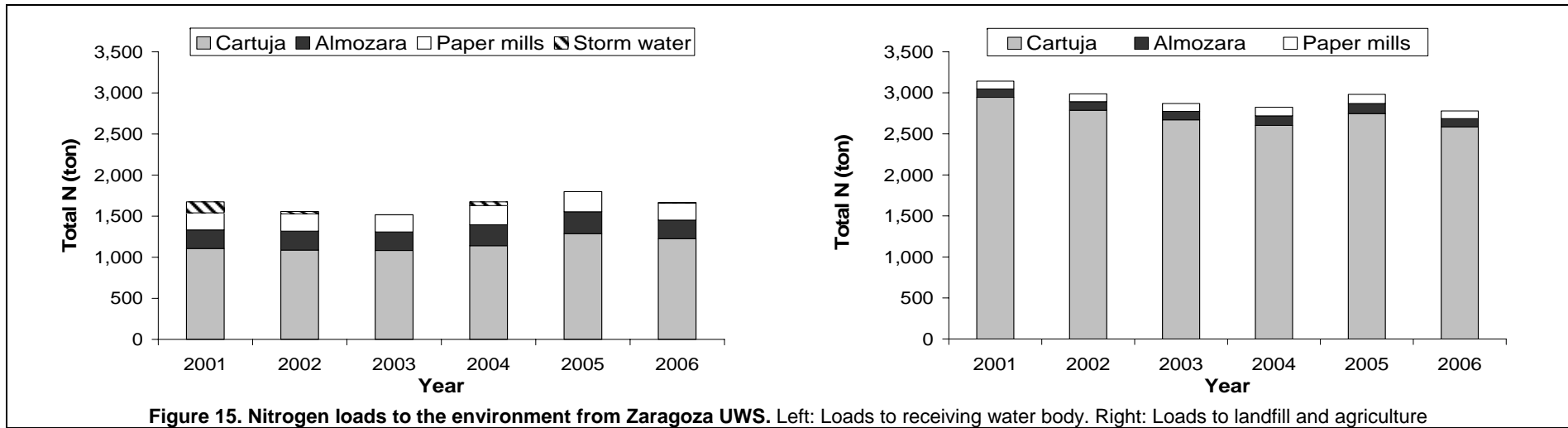

4.3.6 Sludge production

Figure 17 shows the annual production of sludge (dry matter) produced by Zaragoza UWS. Here both DWT and WWT sludge are presented together. Clearly those two are completely different kind of waste and impact the environment in different way. However, solid waste production as such is generally used as environmental performance indicator for urban systems. Hence it is also considered here as well.

It is evident that solid waste production from this UWS has significantly increased from 2001. The reason is that DWTP began dewatering sludge from 2002. From 2003 DWTP sludge becomes the major component of solid waste for the water system. Total solid waste from the water system is around 14,000 ton year⁻¹. According to the Local Agenda 21 Office this amount represents around the 4% of total solid waste produced by the city every year.

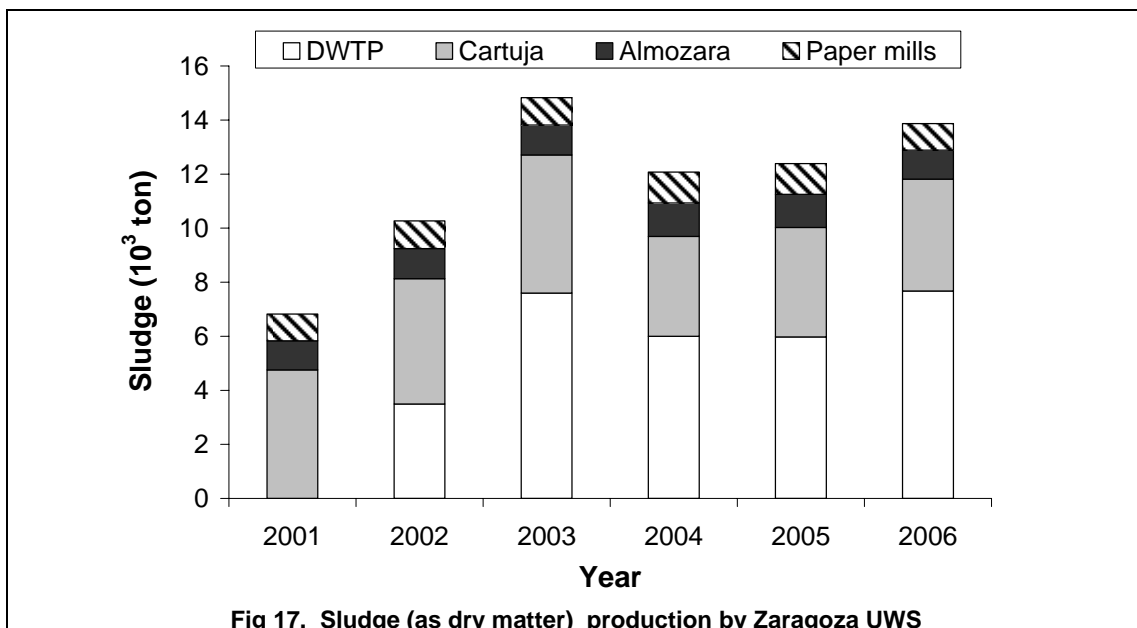

4.4 Zaragoza UWS in the future

The vision of Zaragoza for its UWS has been focused on water supply. The main goal was to reduce water withdrawal to 65 million³ year⁻¹ by 2010 and has already been achieved. Other goal is to reduce unaccounted tap water below 15%, but there is no time horizon for this goal. However this indicator has been reducing 2% per year on average since 2002 when the plan for improving water supply started (see table 2). If the city manages to keep decreasing unaccounted water at such rate, it will reach 15% by 2015.

Other aspects of environmental urban water sustainability are not expressed as goals for the water system. However Zaragoza city signed the Aalborg summit for sustainable European cities. The goals of Zaragoza sustainability vision that apply to the UWS and a list of suggested actions to achieve each goal are shown in table 5.

Table 5. Goals of the Aalborg summit that apply to the UWS of Zaragoza

Goal	Necessary actions to achieve the goal
1 To reduce water withdrawal	Water recycling, infrastructure upgrading (on going action), demand management (demo activity within the SWITCH project)
2 To reduce unaccounted water	Infrastructure upgrading, demand management
3 To improve water supply quality	Shifting to a different raw water source (on going action), shifting to a different DWT technology
4 To contribute to improve the ecological Status of the Ebro River	To reduce pollution loads to the River
5 To reduce dependence on fossil fuels	Shifting to renewable energy sources (depends on National Government Policies)
6 To reduce the ecological footprint	To reduce resource consumption
7 To reduce the production of solid waste	To reduce sludge production

4.4.2 Focus problem and drivers affecting Zaragoza sustainability vision

The tree problem methodology is used here to define the goal of environmental sustainability as the focus problem of Zaragoza UWS. Several drivers that might affect the environmental performance of such system are shown in figure 18.

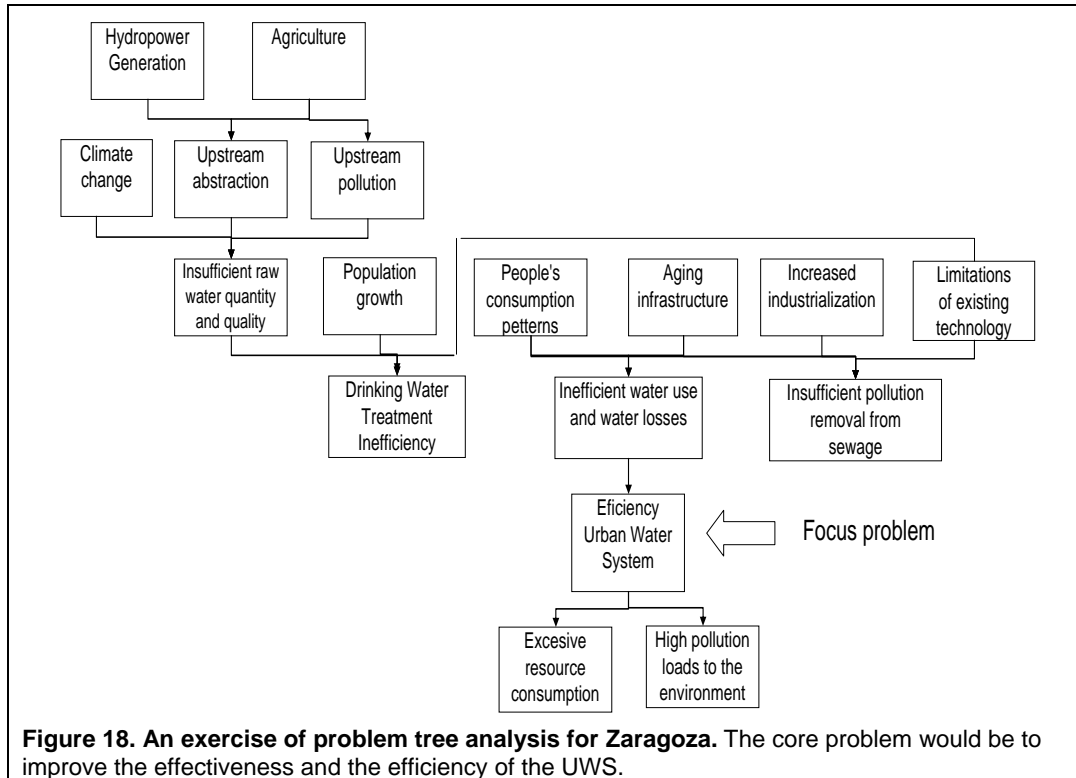

Figure 18. An exercise of problem tree analysis for Zaragoza. The core problem would be to improve the effectiveness and the efficiency of the UWS.

The drivers identified in figure 18 are classified in figure 19 by a matrix of uncertainty vs importance. The criteria for such classification are described next.

Increasing importance →	More important – less uncertain	More important – more uncertain
	<ul style="list-style-type: none"> • Urbanization • Availability of funds • Dependence on fossil fuels • Existing infrastructure 	<ul style="list-style-type: none"> • Climate change • Water abstraction use • Population increase
	Less important – less uncertain	Less important – more uncertain
	<ul style="list-style-type: none"> • DWT and WWT technologies 	<ul style="list-style-type: none"> • Storm water
	Increasing uncertainty →	

Figure 19. Matrix of uncertainty vs importance to classify drivers of Zaragoza UWS sustainability

4.4.1 Criteria for classification of drivers

4.4.1.1 Less important – less uncertain

- Introduction of new DWT and/or WWT technologies is not planned for Zaragoza during the next decade since current infrastructure is being upgraded and costs will still be paid in the coming years.

4.4.1.2 Less important – more uncertain

- According to data analyzed in this report, storm water does not seem to be a determining issue for the environmental performance of Zaragoza UWS, which is also logic considering precipitation and evapotranspiration in this region. Given the erratic precipitation patterns that characterize Zaragoza, the uncertainty level is also high.

4.4.1.3 More important – less uncertain

- Urbanization in Zaragoza is increasing, but it is planned, therefore its uncertainty level is low, its importance for the environmental performance of Zaragoza UWS is high.
- Availability of funds for improving the system is an important issue, but it is assured for the upgrading plans and the education campaigns that are already in place.
- From the data presented here it is evident that the dependency on fossil fuels for electricity production in Spain is still high and it is an important component of the UWS environmental impacts. However Spain has signed the Kyoto protocol and there are already plans to expand the electricity production from renewable sources. Figure 20 shows the expected composition of electric power production market projected by the National Plan on Energy proposed by 2015 in Spain (Ministerio de Industria, Turismo y Comercio, 2007). This composition will reduce the dependence on fossil fuels and also reduces atmospheric emissions from 436 to 320 ton Gwh⁻¹.

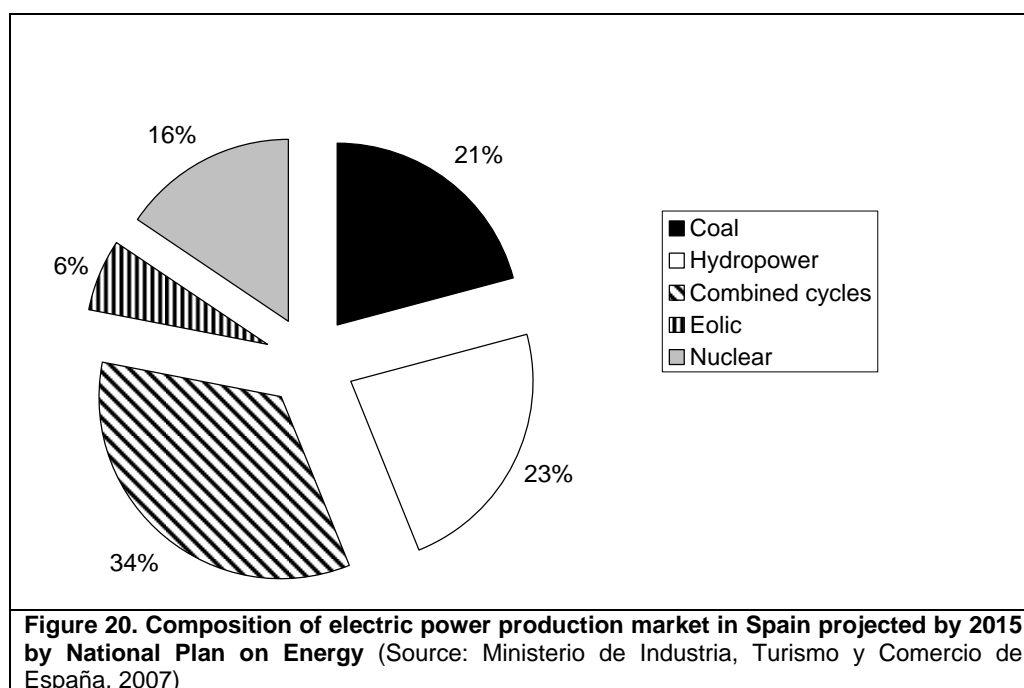

- Infrastructure ageing is one of the most important limitations for Zaragoza UWS, moreover when water efficiency use is considered. However this upgrading has been taking place during the last decade and it is planned to continue during the years to come.

4.4.1.4 More important – more uncertain

- Spain is a country with problems of water stress. In addition to this, the Aragon valley is the driest region in Europe, as it was already mentioned. Therefore the effect of climate change upon the water resources is a major issue and this may threaten the quantity and the quality of the water required by Zaragoza in the future. In addition to this, the environmental impacts of the city upon the Ebro River downstream will be also dependent on the river discharges, which will also be affected by climate change.
- Upstream water use is a major issue for Zaragoza since it can exacerbate the effects of climate change upon water quantity and quality. Additionally, as it was described previously, excess water for irrigation upstream from Zaragoza is responsible for recharging city's groundwater, which accounts for the 23% of current water requirements.

- Population in Zaragoza has increased in a 1% average during the last decade. There is a study about population increase projections, but it ends up in 2008. Therefore it is not clear the rate of population increase in the future years. Therefore this is an uncertain factor that strongly affects both resource consumption (water, chemical products, energy, etc) and pollution loads.

4.4.3 Scenario analysis

4.4.3.1 Setting Scenario

Several combinations of the 4 factors considered as more uncertain and more important are possible. Table 6 shows three examples for possible scenarios. Climate change effects are considered as percentage of projected reduction of water availability in the Ebro catchment by 2020 (Ayala-Carcedo, 2000).

Table 6. Possible drivers scenarios for Zaragoza UWS

Scenario	Climate change	Water use upstream	Population	Classification	
Sc1	0%	<	<	best	unlikely
Sc2	-6%	=	=	bad	unlikely
Sc3	-13%	> 10%	1%	worst	likely

Scenario Sc3 can be considered likely in every aspect since:

- Climate change is expected to reduce water availability in the Ebro basin in 40% to 2060 which means 13% by 2020 if a constant reduction rate is considered (Ayala-Carcedo, 2000).
- The National Irrigation Plan that is about to be implemented in the years to come aims to increase 10% of current irrigated area in Spain by 2015 (MAPA, 2007), which directly means 10% more water abstraction upstream from Zaragoza because irrigation is already the major water consumer in the Ebro Catchment.
- Zaragoza urbanization plan assumes that city will continue expanding and therefore it is very likely that population will continue increasing.

4.4.3.2 Assumptions for Scenario analysis

Zaragoza sustainability vision will be analyzed for the time horizon 2020 under Sc3 scenario considering climate change and Spanish national policies on water as major drivers. Due to time constraints, other likely scenarios are not analyzed. Under Sc3 scenario, several assumptions that can be considered realistic are made:

- From 2002 when water infrastructure started being upgraded, unaccounted water has been decreasing in 7% every year. Funds to continue upgrading are available. In addition to this, demand management is going to be implemented as demonstration activity for Zaragoza within the SWITCH project. Therefore unaccounted water is expected to continue reducing. If current reduction rate is sustained, then unaccounted water will be around 10% of total withdrawal by 2020.
- Since most components of water infrastructure either are being upgraded or have been recently upgraded, there is no possibility that existing DWT and WWT technology in Zaragoza will change before 2020.
- Consumption and production patterns in Spanish society are assumed to stay the same, or will even increase by 2020. Therefore pollution loads to the sewage system will increase at the same rate as population is increasing.

4.4.3.3 Suggested strategy: Industrial water recycling

4.4.3.3.1 Effect of water recycling on water withdrawal

Under Sc3 scenario Zaragoza population is expected to be 14% larger than now by 2020. As shown in figure 21, water withdrawal is expected to reduce from 64 million m³ in 2006 to 56 million m³ in 2020 just as a consequence of infrastructure upgrading, meaning 14% reduction of current water withdrawal. If the city aims to reduce water withdrawal below 56 million m³ by 2020, then also domestic and industrial water consumption must be reduced. Current strategies going on in Zaragoza also aim to optimize water use for landscaping, however this use only represents 5% of total water requirements (including groundwater). Therefore such strategy is not going to have a significant effect.

Presently domestic consumption in Zaragoza is already 110 l person⁻¹ day⁻¹, which is already a low consumption, to reduce it below this level is not very likely. On the other hand, current industrial water needs in Zaragoza are approximately 40% of total water requirements (including groundwater). A suitable alternative for continuing reducing water requirements of Zaragoza city would be recycling industrial water. For this scenario analysis two strategies consisting on 10% and 30% recycling are considered. This will represent additional 2% and 7% less water withdrawal respectively (see figure 21). This strategy considers both tap and groundwater.

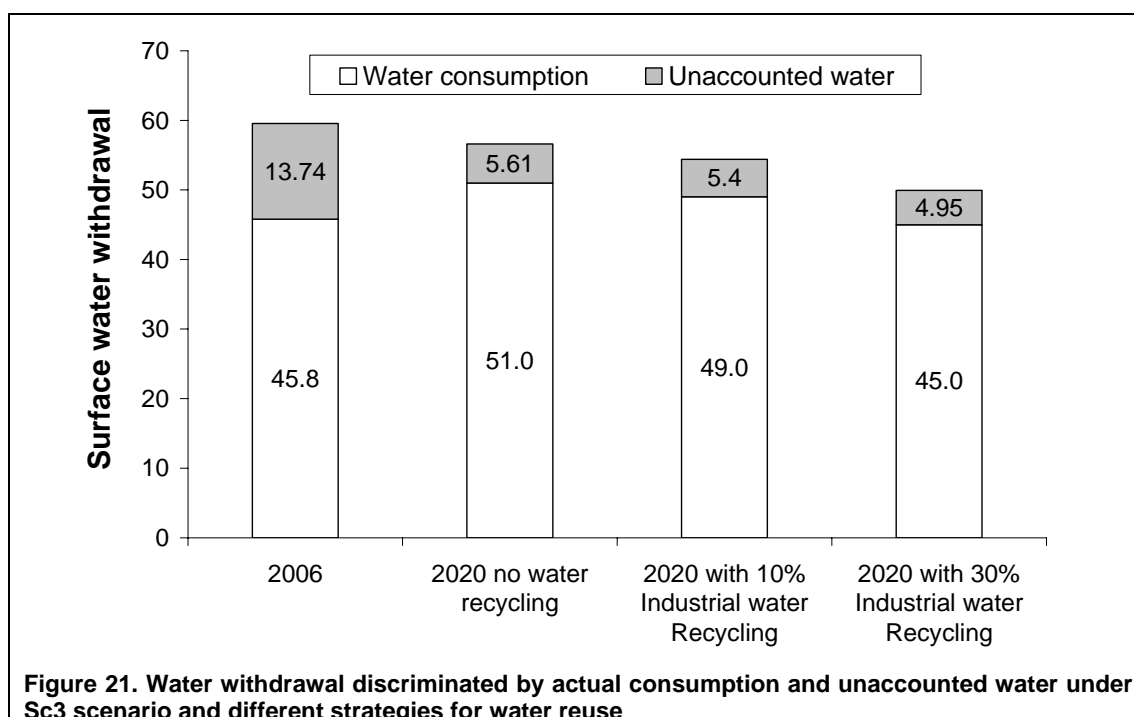

4.4.3.3.2 Effect of water recycling on chemical products consumption

Two factors have an effect on the use of chemical products for DWT: 1) water withdrawal and 2) raw water quality. The effect of projected water withdrawal may simply be calculated from figure 21. The effect of raw water quality is more complex since it is the consequence of several variables such as pH, SS, DOM, etc.

The effect of water quality on the future use of chemical products is very relevant for Zaragoza since a new raw water source will be used from 2008. The Yesa reservoir is expected to provide a higher water quality than the Ebro River. In order to get a hint about how much less chemical products will be necessary to treat water from Yesa reservoir as compared to the Ebro River a regression analysis between chemical products dose per m³ and raw water quality was performed. The considered variables of raw water were DOM (as UV absorbance) and SS. Unfortunately no significant correlation was found (data not shown). In addition to this, a comparison between the same two variables between Canal Imperial and Yesa reservoir was made. It was found that the two sources have very different values for suspended solids, but the values for DOM are quite similar (data not shown). Therefore the only assumption that can be made concerning chemical products consumption for water supply in Zaragoza is that it will decrease according to water withdrawal.

4.4.3.3 Effect of water recycling on Energy consumption

If water withdrawal is expected to decrease by 2020 then electric energy consumption is also expected to decrease. However, energy consumption of water facilities has got two components, a fixed value and a variable value that is proportional to the inflow. In order to identify such components a regression analysis between water inflow and energy consumption was performed for the water supply system in Zaragoza. The correlation is expressed by $r^2 = 0.2$ (data not shown). Meaning that 80% of energy consumption of the water supply process can be considered as a fixed value and 20% can be considered as flow dependent.

The variable energy consumption for the water supply process is 0.1 Gwh per million m^3 . The energy consumption of pumping groundwater in Zaragoza is around 0.02 Gwh per million m^3 . Recycling industrial water means increasing energy consumption because pumping will be necessary. An assumption here is made that recycling water will consume more energy than groundwater pumping, but of course much less than the variable energy consumption by water supply. This assumed value is 0.03 Gwh per million m^3 . Figure 22 shows an analysis of energy consumption by Zaragoza UWS for 2006 and for scenario 2020 considering these values as well as different levels for the industrial water recycling strategy.

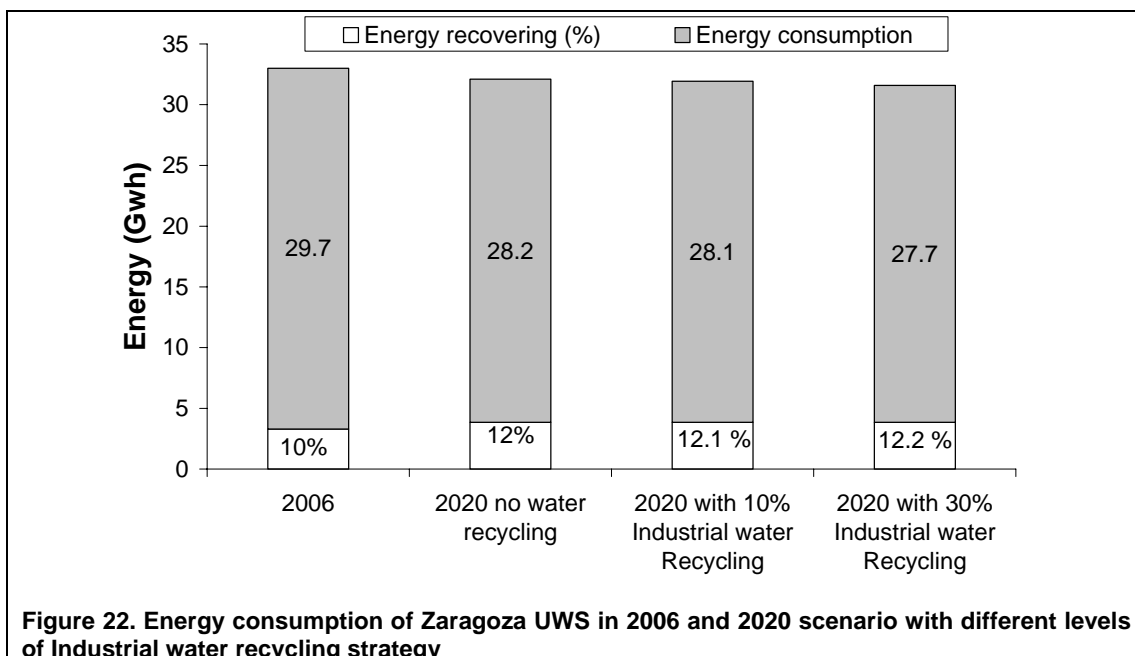

Water recycling will result in less energy consumption for Industries using tap water since recycling is less costly than tap water supplying. For industries that do not use tap water, recycling is more expensive than extracting groundwater. Their additional

consumption would be 0.16 and 0.51 Gwh per year for 10% and 30% recycling respectively. However the energy savings supposed by tap water recycling are so significant, that Zaragoza taken as a whole system will be actually consuming slightly less energy if Industrial water recycling is implemented (see figure 22).

4.4.3.3.4 Effect of water recycling on CO² emissions to the atmosphere

Figure 23 shows an analysis of CO² emissions, considering the described figures for energy consumption, the National Plan on Energy and the expected increase on organic matter loads to the sewage by 2020.

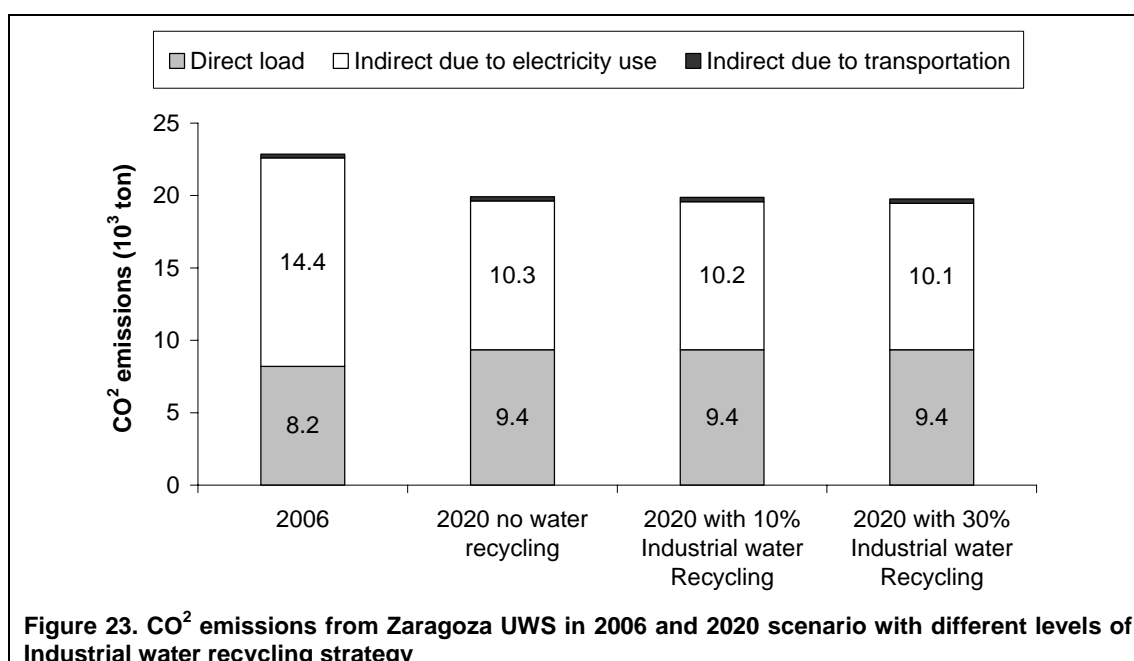

As previously described, the major contribution to atmospheric emissions by Zaragoza UWS is indirectly by electricity use. As expected from figure 23, the joint effect of the National Energy Plan and the reduction on energy consumption supposed by decreasing water withdrawal, imply a significant reduction of atmospheric emissions from 22,600 ton in 2006 to 19,700 in 2020.

As organic matter loads to the sewage are expected to increase 14% (see section 4.4.3.3.4) direct emissions will increase likewise, going from 8,200 to 9,400 ton per year. Indirect emissions by transportation of chemical products and sludge seem negligible in the figure, but those will increase from 250 in 2006 to 291 ton in 2020. The savings on energy supposed by industrial water recycling would represent an additional reduction of 50 and 100 ton per year for the 10% and the 30% strategies respectively.

4.4.3.3.5 Effect of water recycling on pollution loads to the Ebro River

Under the assumptions previously described it is expected that 14% larger pollution loads will be dumped into 14% less sewage volume by 2020. Hence BOD, nutrients and heavy metals will be 28% more concentrated in the sewage. If industrial water recycling is considered then pollutant concentrations in sewage will increase 30% for 10% recycling and 37% for 30% strategy. As consequence of this increased concentration in the inflow, higher removal efficiency at WWTPs would be expected. In order to calculate how much this increasing efficiency would be a regression analysis between pollutant concentrations and removal efficiency was performed for all WWT facilities in Zaragoza. However, no significant correlation was found ($r^2 = 0.028$, data not shown). Therefore, the assumption is made here that with the current WWT technology and current societal production and consumption patterns, pollution loads to the Ebro River will increase 14% by 2020, even if unaccounted water is reduced and even if industrial water is recycled.

4.4.3.4 Assessment of water quantity and quality for Zaragoza in the future

Considering the figures previously described for Sc3 concerning upstream water use and the effect of climate change upon water availability in the Ebro catchment. An assessment of the risk for water availability in Zaragoza was performed. Here an additional scenario for the year 2060 was projected. From figure 24 it is evident that Zaragoza can rely on Yesa reservoir as raw water source for the years to come since Zaragoza requirements projected by the year 2060 with increasing population and no water recycling are well below the projected capacity of the reservoir, even under the worst climate change and water extraction scenario.

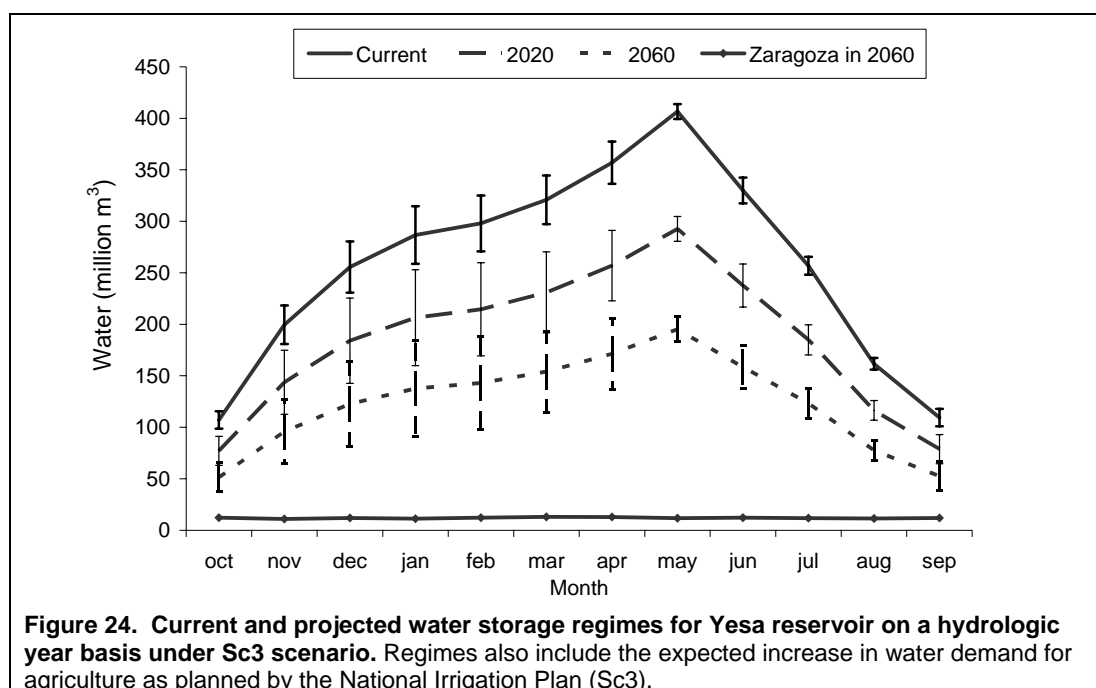

In this analysis total Zaragoza requirements are included, even those that are currently fulfilled from groundwater. The reason is that National Irrigation Plan also considers the need of upgrading current irrigation technologies to minimize loses. This will reduce the groundwater recharge in Zaragoza and the water table might eventually drop so that it is not that feasible anymore. In such scenario, either the whole city becomes dependent on tap water or the activities that currently use groundwater will turn to the Ebro River, whose discharge will be already considerably reduced by that time.

Water quality of Yesa reservoir is more difficult to project. However it is possible to consider TP concentrations as reference point. Current Yesa average TP concentrations on year basis are 21 ug/l. If current inputs are expected to remain constant, then by 2020 average TP concentrations might rise to around 40 ug/l and 60 ug/l by 2060. This situation encompassed with increasing temperature and radiation (due to climate change) would increase the risk for the reservoir to experience algal blooms, which might negatively affect water supply quality for Zaragoza.

4.4.3.5 Setting priorities for pollution loads

This report provides insights about the environmental impacts of Zaragoza UWS operation on a year basis. However such impacts are not constant all over the year and might vary seasonally. In fact, even if pollution loads remained constant all over the year, there will be a seasonal variation of the receiving environment. This is more evident for the water bodies and is remarkable for the Ebro River which exhibits an important variation of its discharge along the year. The current hydrograph for the Ebro river on a month average basis is provided in figure 25. This figure also shows the worst climate change scenario expected for water availability in this basin for the year 2020 and the year 2060.

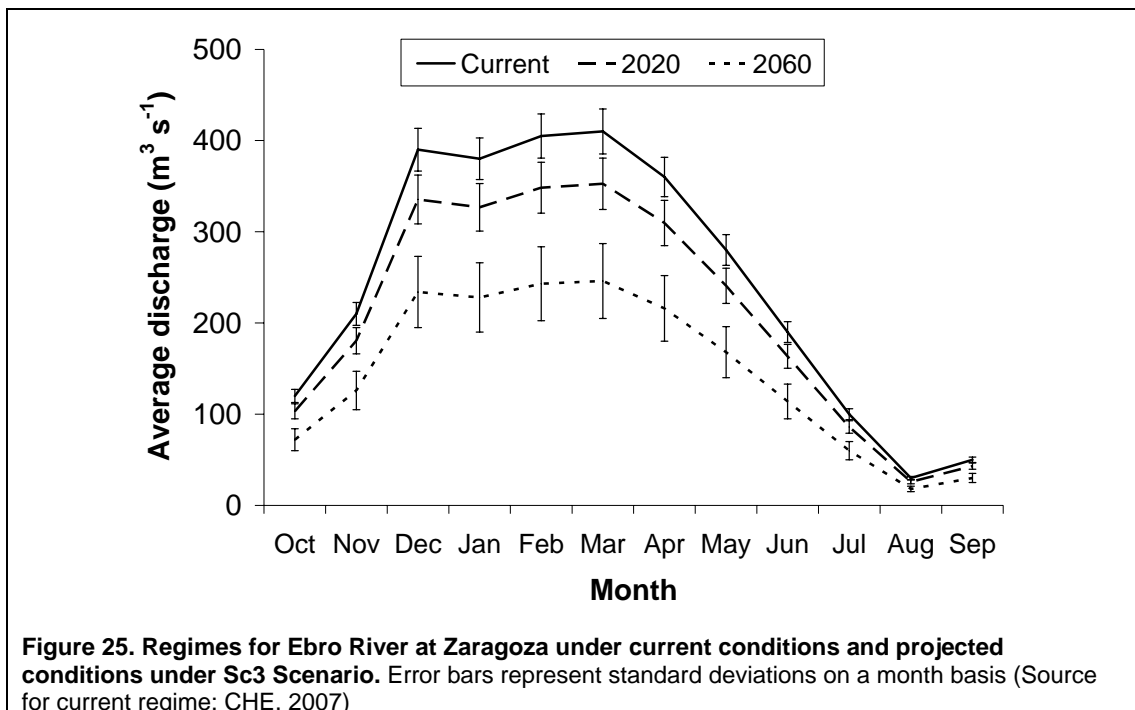

In current conditions maximum discharges of nearly $400 \text{ m}^3 \text{ s}^{-1}$ are expected between December and April. Minimum discharges are expected during summer time, especially in August, where they can be as low as $30 \text{ m}^3 \text{ s}^{-1}$. This also means that the impact of Zaragoza UWS upon the Ebro River is not constant all over the year and it reaches a maximum in August. Figure 26 provides an example of the seasonality of this impact taking total phosphorus as an example.

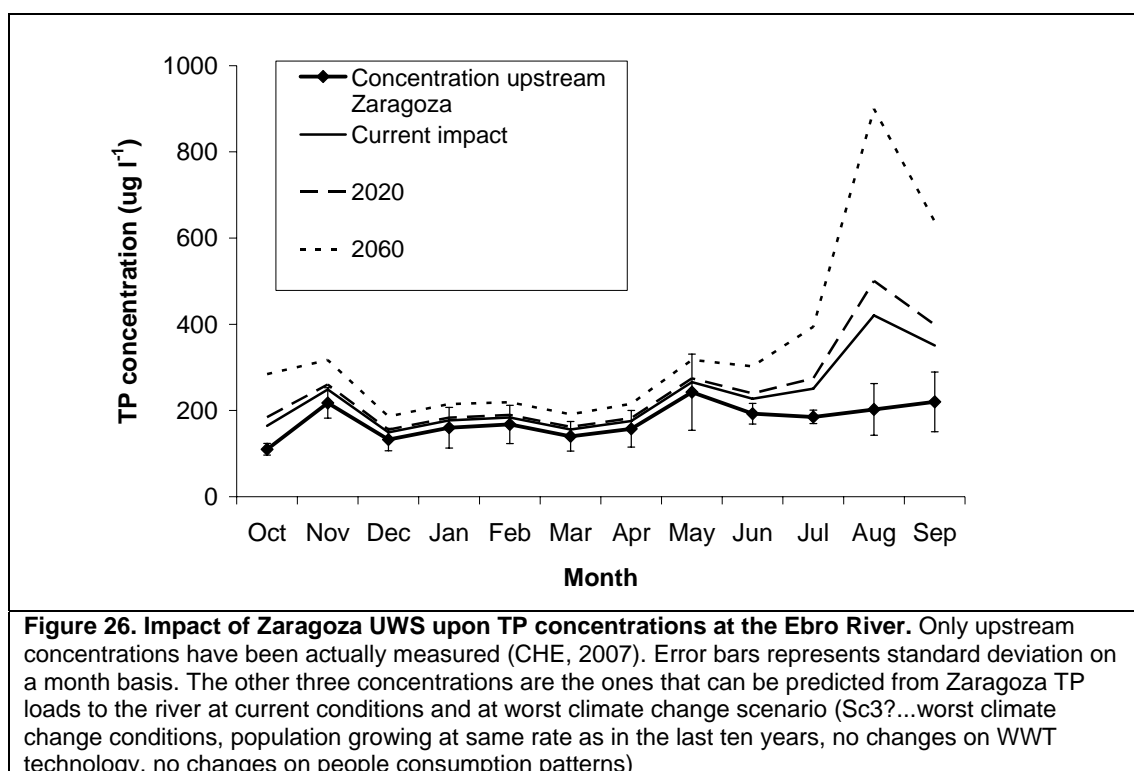

TP concentrations in the Ebro River, upstream from Zaragoza, range between 100 to 200 $\mu\text{g l}^{-1}$. Under current conditions the city does not have a significant impact on the river from October to May, but from June onwards the impact becomes more important and it may raise the TP concentrations up to 400 $\mu\text{g l}^{-1}$. In August when—as previously described—river discharge may drop down to 30 $\text{m}^3 \text{s}^{-1}$. For the 2020 scenario the pattern is quite similar, but for the 2060 scenario August TP concentration goes up to 900 $\mu\text{g l}^{-1}$, which is more than three times the present upstream concentration.

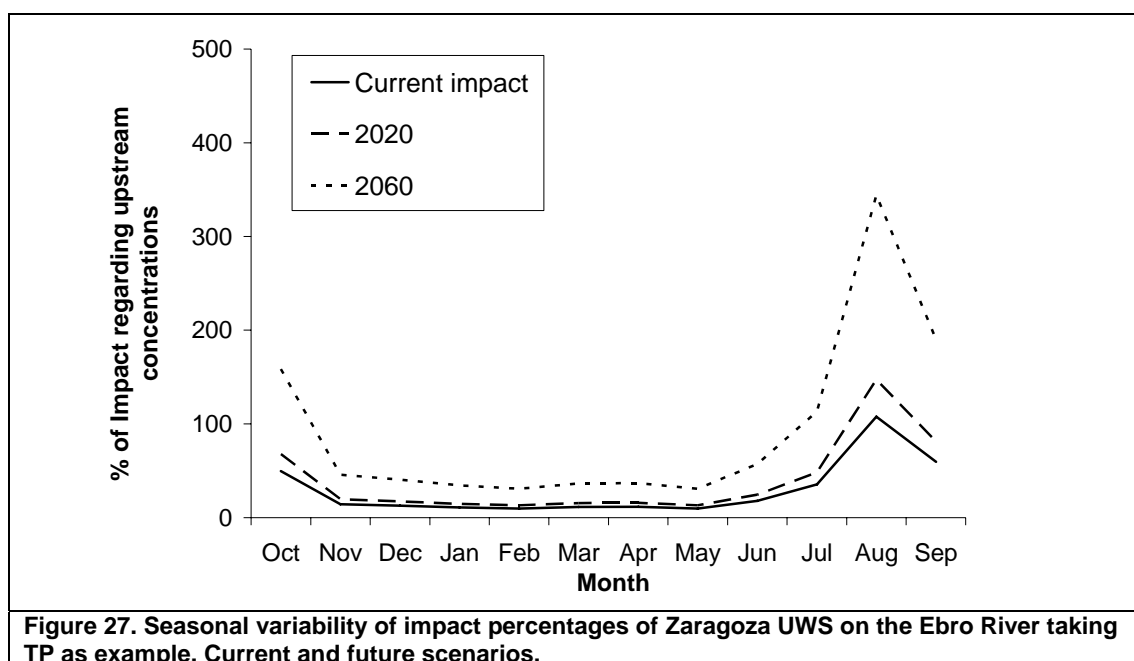

If the differences between upstream concentrations and the predicted ones are converted into percentages, then these can be called impact percentages on the river and might possibly be used as indicators for sustainability. Figure 27 shows such percentages, again with reference to TP as an example.

Current scenario shows an impact below 20% from November to May. Again in June it begins increasing and it goes up to 110% in August. For the 2020 scenario the peak impact also in August is nearly 150%, and finally the seasonal impact peak for the 2060 scenario goes up to 350%.

Table 7 shows the values of these seasonal impact peaks for BOD, COD, TN, TP and Heavy Metals at: 1) current, 2) 2020 and 3) 2060 scenarios. Interestingly the highest value goes to TP with 110% for present scenario, followed by COD with 50%, TN with 33%, Heavy metals with 17% and finally BOD with 13%.

Considering these results it would be possible to say that priorities for Zaragoza UWS to increase its environmental performance, at least with regard to the receiving water body are as follows:

1. Phosphorus
2. Non biodegradable organic matter
3. Nitrogen
4. Heavy metals
5. BOD

This is a very interesting outcome that reflects several internal aspects of Zaragoza UWS as well as its relation to the surrounding environment.

Secondary WWT via activated sludge is a technology for BOD removal and it works quite well on this regard. Therefore it is possible to say that improving BOD removal is not a priority for this UWS.

Since activated sludge is a biological treatment it does not work that well to remove non biodegradable OM, remaining COD in treated sewage has got a relatively high impact on the receiving water body.

Zaragoza WWT system is not designed to remove nitrogen. However biodegradable OM removal is also removing about 40% nitrogen from sewage. The remaining 60% is still high but it does not seem to have an important impact on the Ebro River, which might be explained by the fact that nitrogen concentrations in the river are already high (see table 7).

Concerning heavy metals, again it is important to say that Zaragoza WWT system is not designed to remove those, nearly 40% are retained by the sludge though. Also untreated Zaragoza sewage does not contain high heavy metal concentrations. Therefore this impact is not that significant.

Concerning phosphorus it is possible to say that 68% of Zaragoza WWT system (Cartuja plant) is actually designed to remove phosphorus. However the effectiveness of this technology is just around 80%, in addition to this, the combined impact of Almozara and paper mills WWTPs, which do not remove nutrients, is so important that TP has got a large impact on the Ebro River. Therefore reducing phosphorous loads may be considered as the priority for improving Zaragoza UWS with regard to the Ebro River.

Table 7. Seasonal impact peaks of Zaragoza UWS upon the Ebro River under present conditions and worst climate change scenarios for 2020 and 2060. These impacts are calculated on the basis of current pollutant concentrations in August, when river discharge is at minimum and projected river flows for the same month in 2020 and 2060. (see figure 27). So this can be considered as the maximum impact that Zaragoza might annually have upon the Ebro River

Parameter	Current concentrations upstream from Zaragoza during summer time	Current impact of Zaragoza		2020		2060	
		Expected raising of Concentration	%*	Expected raising of Concentration	%*	Expected raising of Concentration	%*
BOD (mg l ⁻¹)	6.4 – 10.4	7.5 – 11.5	13	7.9 – 11.9	18	6.7 – 13.7	20
COD (mg l ⁻¹)	5.2 – 14.4	10.1 -19.3	50	11.8 – 21.0	67	19.6 – 28.8	147
TN (mg l ⁻¹)	2.8 – 7.9	4.6 – 9.7	33	5.2 – 10.3	45	7.9 – 13.0	95
TP (µg l ⁻¹)	120 – 200	326 - 406	110	396 – 476	173	718 – 798	374
Heavy metals (µg l ⁻¹)	113 – 324	152 - 363	17	165 – 376	24	225 – 436	51

* The percentage in this table refers to the increasing with respect to the current value.

5 Discussion

The main goal of water management in Zaragoza in the recent years has been to reduce fresh water withdrawal below 65 million m³ year⁻¹. The time horizon for this goal was the year 2010 but it has been already achieved in 2006. In addition to this, unaccounted water in Zaragoza has been significantly reduced along these years from 40 to 32%, but it still remains too high and the volume of actual leakages is still unknown. This particular aspect is to be assessed by the SWITCH project in Zaragoza as a demo activity. However it is possible to say that water supply is significantly and consistently improving in the city. The open question now is whether this improving makes the urban system as a whole more sustainable.

5.1 Sustainability of UWS

The starting point for assessing sustainability of urban water systems is a definition of the basic services the system is supposed to provide, before start looking for alternatives to improve existing technology (Larsen and Gujer, 1997). The services the urban system should meet are basically three:

- Reliable supply of safe water to all residents for drinking, hygiene and household purposes
- Safe transport and treatment of wastewater
- Adequate drainage of impervious areas

Zaragoza UWS is currently providing these basic services. However in a second level, there are some requirements for such services to be considered sustainable that also need to be assessed. Lundin (1999) propose the following list:

- a. Technical performance: defined as the degree of effectiveness (degree of goal achieving) and efficiency (resource optimization).
- b. Reliability, flexibility and adaptability: defined as the capacity of continuing on providing the service when unexpected events occur, encompassed with the potential for the system to change.
- c. Durability: referring to infrastructure
- d. Environmental protection: pollutant emissions as low as required to maintain the quality of the environment (atmosphere, aquatic ecosystems and soil)
- e. Cost-effectiveness: cost recovering of the service and affordability of investments

- f. Skilled and sufficient staff: to operate and maintain the system. But also personal with knowledge on microbiology, chemistry and ecology. Gender diversity is also required.
- g. Social dimension: the service should be socially and culturally acceptable
- h. Public awareness: on sustainable behavior

This work has quantitatively analyzed the aspects a. and d. of Zaragoza UWS. One important aspect that has been neglected in this research is the water infrastructure, which is determinant for sustainable urban planning in terms of scale, use of space and longevity (Lundin & Morrison, 2002). Nevertheless for the SWITCH project it might be interesting to evaluate, for instance, the environmental impacts and the long time perspective of the ongoing projects on infrastructure upgrading in Zaragoza.

5.2 LCA as a tool for Sustainability assessment

The methodology used for this research is based on the LCA methodology, that is being extensively used to assess environmental sustainability of Urban Water Systems and it has proven to be very useful. However it has got some important drawbacks as well. For instance some authors criticize the fact that it overlooks important geographic variations such as the resilience of receiving water, also some qualitative aspects, such as sludge quality or ecosystem health are difficult to assess with LCA. Finally, water consumption is not incorporated in the analysis, therefore, it can be considered as a useful tool, but complementary information should also be included for a more complete approach to evaluate urban sustainability (Lundin, 1999)

The present work evaluated the sustainability aspects of water extraction, but also resource consumption and pollution impacts. Such values are presented as indicators for environmental sustainability with the main purpose of providing comprehensive and quantitative information to decision makers in Zaragoza.

5.3 Sustainability Indicators

There are many indicators that are currently being used by water organizations around the world to assess their performance and they are suggested to be sustainability indicators but only few actually are (Lundin and Morrison, 2002). For instance percentages of pollution removal at WWT facilities are often suggested as sustainability indicators but those provide information only about the performance of existing end-of-pipe technologies. Percentages of removal can for instance remain

the same over time while both pollution concentrations and pollution loads to the environment are actually increasing. Additionally, higher effectiveness may decrease the efficiency, since more resources are required per amount of pollutant that is removed. In this sense, total loads are more useful indicators, since they can actually reflect, not just the technical performance of WWT, but also whether pollution sources within the city are controlled. An example of this is the management of heavy metals and other toxic substances by Local Agenda 21 Office in Zaragoza. Being aware that the existing WWTPs in the city are unable to treat such substances, they are controlling industrial activities to prevent those to enter the sewer system. Such control on industrial activities will be reflected in the total heavy metal loads, but it won't be quantified by the percentage removal at all.

In this report the definition of sustainability indicator from Lundin (1999) is used as reference point: "A sustainability indicator should link (or at least balance) different areas of society e.g. life styles, economy, resource use and environmental problems or relate to a sustainability target. Consequently, an indicator of environmental sustainability can be defined as an environmental performance indicator (EPI) where the target reflects a sustainable situation. It should ideally provide an early warning for potential problems, being understandable and usable, within the urban water sector and/or for the public and information for calculated should be available".

Basically most data presented here more or less fulfill this definition and is therefore are suggested to continue being used as part a pool of sustainability indicators Zaragoza Urban Water System. Evidently these indicators relate only with the environmental dimension of sustainability. The social and economic dimensions will require different ones. Also additional indicators would be necessary to fully evaluate the environmental performance of the system. A list of indicators derived from this work is provided next:

1. Water withdrawal
2. Water consumption
3. Energy consumption
4. Chemical product consumption
5. CO₂ direct and indirect emissions
6. Pollution loads to the Ebro River (TP, TN, BOD, COD and Heavy Metals)
7. Percentage of Impact upon the river by target pollutants (TP, TN, BOD, COD and Heavy Metals)

8. Sludge production
9. Nutrient recycling to agriculture
10. Heavy metals loads to agriculture

So far water withdrawal and water consumption have already been discussed, but there is major component of water withdrawal which is not being considered by Zaragoza municipality within its goals is groundwater, which is under the authority of the Ebro River Confederation (CHE). Ground water is currently fulfilling 23% of water requirements for Zaragoza city. Major consumers are industries not connected to sewer system, corresponding to two paper mills owning private WWTPs.

Groundwater preservation is one of the criteria used to evaluate environmental sustainability. Being relatively cheaper and usually of higher quality than surface water, groundwater reserves are being over-exploited in several European countries, leading to the drying up of spring waters, destruction of wetlands and saline intrusion of aquifers in coastal zones (Hellstrom et al, 2004). All those problems have been indeed taking place in Spain, and especially in the Ebro Delta, which is a Ramsar site and it's considered as the second most important natural reserve of the country (CHE, 2007).

The role of groundwater extraction on the environmental impacts of Zaragoza city on the Ebro Catchment is difficult to assess because this groundwater is not part of the natural water cycle, but the result of inefficient use of water for irrigation upstream. According to the Ebro River Working Group this artificial recharge is also feeding the Ebro River flow (personal communication). Considering that 177,000 ha in Zaragoza province are currently irrigated and percolation is around $10,000 \text{ m}^3 \text{ ha}^{-1}$ the influence of Zaragoza upon this artificial aquifer is probably negligible, but this would require further research.

In addition to quantity there is also a matter of quality that requires to be assessed concerning groundwater. First, due to its origin, this groundwater is contaminated with nitrates (Mema et al, 2006) and probably also with pesticides. Additionally there is a contamination by persistent chlorinated substances in one of the largest industrial polygon of Zaragoza city. This is consequence of the inadequate practices of a large company that used to work there between 1976 and 1985; and it was discovered in 2006 (CHE, 2006). The implications of speeding up the cycle of this polluted groundwater in Zaragoza are still unclear. Zaragoza municipality and CHE

must work together to make clear not just this aspect, but in general all matters related to groundwater planning and management.

Concerning the indicators not related to water withdrawal but to water pollution. Zaragoza city introduced WWT between late 1980s and early 1990s in order to minimize pollution loads to the Ebro River. This time period was not analyzed here. If the time horizon were expanded over two or three decades it would become evident that the city reduced has reduced its oxygen demanding loads to the Ebro River. However there are yet several environmental burdens that require attention regardless the compliance with local and national regulations.

During the time period of the present study the consumption of energy and chemical products, as well as the pollution loads to the Ebro River and the atmospheric emissions have remained more or less constant. Optimizing the water system to reduce such environmental impacts should be expressively included within the goals for water management. To become sustainable WWT systems have to evolve from a reactive approach aimed to remove environmental pollutants to process optimization where the focus is cycling materials as well as saving energy (Lundin & Morrison, 2002).

5.4 Sustainability vision

Zaragoza has committed to a list of environmental goals derived from the Aalborg summit for sustainable European cities. This work suggests seven of such goals to be specifically included as environmental goals for the urban water system. In order to do so, the whole Zaragoza sustainability vision has to be adjusted to the SMART principle: Specific, Measurable, Acceptable, Realistic and Time bound (Assinmacopoulos, 2007). This principle was implicit in the goal for reducing water withdrawal and it showed to be very successful.

Setting sustainability goals would also require setting action priorities. From the results presented here it is possible to conclude that energy consumption and its indirect impacts on atmospheric emissions would be a priority, specifically for WWT system. Technical options for optimization should be explored by the municipality. But due to time constraints, such options were not explored by this research work. However a follow-up to the National Plan on Energy would provide some hints about how to reduce the atmospheric emissions derived from electricity production. Since this resource is subjected to an open market dynamics, the municipality could

indirectly influence its CO₂ emissions by selecting the company that is using more sustainable sources.

Concerning pollution loads, a methodology to set priorities, based on comparing upstream concentrations vs expected concentrations downstream was used in this work and the seasonality of such impacts was included as an important component. From this methodology BOD, heavy metal and nitrogen loads from Zaragoza apparently don't have an important impact upon the water quality of the Ebro River. Therefore such loads should still be considered, but a priority action for sustainability would be reducing Phosphorus loads considering the impact of more than two fold increase on downstream concentrations. This impact is also expected to exacerbate as a consequence of climate change. A reasonable goal would be, for instance: "to reduce by half the emissions of phosphorus to the Ebro River by the year 2020".

The methodology based on impact percentages seems to be straight forward and it could be used to also evaluate the impacts of heavy metals on agriculture soil. But it has got several drawbacks because it could lead to the wrong assumption that, if the environment is already polluted it wont be that important to produce more pollution. This is of particular importance when the effect of, for instance, atmospheric emissions on global change is considered. Additionally, this methodology does not consider the fact that environmental impacts are not necessarily linear to the scale of loads. This is particularly valid for heavy metals and for persistent pollutants in general. In such cases, other factors such the dispersion of pollutants, the exposure, the potential for bioaccumulation and biotransformation, as well as dose-response functions should be of major concern.

In addition to waste water, storm water is also considered as a major component of the urban environmental burden (Ahlman, 2006). The present study included a rough estimation of the possible pollution loads from storm water. Due to the lack of data for storm water quality, such estimation is probably far from reality since pollution loads were assumed to be the same as for untreated sewage, but heavy rain events are rare in Zaragoza, therefore it is reasonable to expect that large loads of pollutants accumulate in the streets and buildings and they are washed away by rain water when heavy rain events take place. The resulting runoff must have a very different composition as compared to the dry period sewage. Additionally, the methodology used here to calculate potential overflows is inaccurate since daily precipitation was used as input data. It is evident that two different days with same cumulative value

for precipitation might have completely different hydrographs that, may or may not, lead to sewer overflows. Finally the expected inflow to WWTPs used for storm water calculation is not a reliable value due to the lack of data concerning parasite flows to the sewer system from irrigation channels and overflows from breaking pressure tanks. Therefore the pollution loads from storm water presented here are not to be interpreted as actual impacts but rather as potential scenarios. Further studies for Zaragoza concerning this matter are required.

5.5 Drivers for sustainable urban water planning and management

With this overview of current situation of water management in Zaragoza it is now valid to discuss the drivers that will contribute to define the future of water management in the city. There are some internal drivers that are under the control of Zaragoza planning, such as urbanization, population increase and availability of funds. But cities are far from being isolated systems and they are in fact very much affected by local, national and global processes at environmental, social, political and economical level. Therefore a more comprehensive analysis it is important to widen the perspective both in geography and time. Major external drivers for water management in Zaragoza that have been considered here are National Policies (National Plan on Energy and National Irrigation Plan) and Climate change.

The concern of Zaragoza about water withdrawal makes sense since between 30-60% of Spain is at immediate risk from desertification and the Ebro Valley at Aragon is already the driest inland region of Europe (UNCD, 2007). Under current trends is very possible that Zaragoza will still continue to reduce its fresh water withdrawal via infrastructure upgrading. However, if a further reduction is pursued then additional strategies will be required. Ongoing strategies in Zaragoza also aim to optimize water use for landscaping, but this use only represents 5% of total water requirements (including groundwater). Therefore such strategy is probably not going to have a significant effect. Presently domestic consumption is already $110 \text{ l person}^{-1} \text{ day}^{-1}$, which is already a low consumption. On the other hand, industrial consumption in Zaragoza is approximately the 40% of total water requirements (including groundwater). In this report industrial water recycling is proposed as a suitable alternative to continue reducing water withdrawal. This alternative has not been considered by the city yet because extracting ground water is technically more feasible and economically cheaper. However this seems to be the only possibility to continue reducing water consumption, considering the constraints of reducing domestic consumption already have.

A likely scenario for the year 2020, considering different levels of water recycling was analyzed here, and the probable performance of the UWS under the most negative predictions for climate change and upstream water extraction was assessed by means of the sustainability indicators previously presented and discussed.

According to the scenario assessed here, water from Yesa reservoir will remain available for the city and it will be able to fulfill all requirements during the next 50 years, even under worst possible scenario for climate change and irrigation. However, as consequence of very low volumes during summer time, coupled with expected increased radiation and temperature there is some possibility for algal blooms that might threaten drinking water quality in the years to come. Under this scenario, water from Ebro River will be even more unsuitable for drinking purposes. Therefore Zaragoza will have to completely rely on the Yesa reservoir to fulfill its water demand.

In current conditions it seems also that ground water supply for Zaragoza is granted. However the National Irrigation Plan that is about to be implemented has the purpose of upgrading the existing irrigation technology to optimize water use. If increasing evapotranspiration is also expected due to climate change (Ayala-Carcedo, 2000). As consequence it is probable that groundwater recharge for Zaragoza will not remain at the current rate, and the water table will probably drop down and ground water extraction will not be as feasible as now, but this is not possible to know now since there are no studies about groundwater recharge in this aquifer. Such studies are urgently required and this is partially the subject of the Ebro River Working Group (2007).

The recycling water strategy proposed here would obviously have a direct benefit upon water withdrawal. Also a slightly positive effect is expected on energy consumption and thereby also on CO₂ emissions to the atmosphere. No effect of this strategy is expected on pollution loads to the Ebro River neither to agriculture soil. In fact if population and industrial activities continue to increase, even under a reduction of water withdrawal scenario, pollution loads to the environment are expected to increase likewise. Therefore, with current WWT technology and societal behaviors it will be possible to improve just some aspects of the environmental performance of the system.

Along this work it has been stated that sustainability of urban systems is a broad concept involving more than just the technical components and the end of pipe solutions to reduce pollution. But so far, only these technical aspects have been discussed. There are, of course important links between society and environment that are the focus of research on sustainability. For a long period, industries were the target of environmental issues. Today, households are recognized to contribute about 50% of the chemicals and metals ending up in wastewater. Domestic use of water is also a focal point for reducing urban water consumption. Minimizing hot water use is of particular interest, since it represents 15% of the households' overall energy use (Krantz, 2005).

Urban systems nowadays are characterized by an alienation of households from nature. Specialized organizations are responsible of water supply and WWT, and hence they are seen as responsible for the environmental impact, the effect of household routines is usually overlooked (Krantz, 2005). Sustainability is very much about using fewer resources at every level of society. In this sense sustainable water organizations would be the ones that, in addition to optimizing technical performance also promote public awareness on sustainable practices. It is possible to say that municipality and other stake holders in Zaragoza (mainly NGOs) have been particularly successful on promoting sustainable practices regarding water consumption at industries and households. As mentioned before, public awareness campaigns in this city reduced water withdrawal in about 6 million m³, which was acknowledged by Habitat UN as one of the 100 successful projects concerning urban sustainability worldwide.

Public awareness also demonstrated to be in a high level one in 8th October 2000, around 400,000 people (more than 60% of Zaragoza's population) went to the streets in order to protest against the National Water Plan proposed by the former national government to divert around of a billion cubic meters of water each year from the River Ebro to arid regions on the Mediterranean zone of the country. The plan was not implemented by the current government.

It can be concluded then, that Zaragoza citizenships are very much aware about water related issues and this is of a high potential to improve the overall environmental performance of this UWS.

5.6 Set vs achieved goals for this research

It is possible to say that the goals set for this research were achieved on a large proportion. A total water balance for the UWS was performed, although some sub-balances could not be closed due to missing data. Energy and chemical products consumption were fully calculated. Pollution loads to the Ebro River in terms of BOD, COD, nutrients and heavy metals were quantified. A quantification of toxic organic substances would be also necessary, but it was not possible due to the lack of information. According to its purpose, this work is going to serve as baseline information for further assessment of sustainable development for this UWS.

It is possible also to say that goals were surpassed regarding the future perspectives for Zaragoza UWS derived from the scenario analysis, which was not part of the initial goals for this research. However, this scenario analysis can be considered incipient because it only focuses on the aspects related to the collected data. The suggested strategy is just a technical solution that could be useful, but it has been included in this work basically as an exercise in order to extract more information from the provided data. However, this scenario analysis has defined some important problems that Zaragoza might face in the future. Comprehensive strategies to cope with such problems are to be set by all important stakeholders in Zaragoza and the SWITCH project would contribute with important initiatives to the process. A follow-up of the parameters presented here as sustainability indicators will contribute to assess the success of the set strategies.

6 Conclusions

- 6.1** The present work evaluated the sustainability aspects of water extraction, resource consumption and pollution impacts by means of LCA, which showed to be a useful methodology even when the impact assessment phase is not applied. However, complementary information such as surface water withdrawal, water consumption, ground water extraction, water leakages in distribution network, etc should also be included for a more comprehensive approach.
- 6.2** Zaragoza has been successfully reducing fresh water withdrawal by means of integral strategies involving infrastructure upgrading and promotion of public awareness. The success of these projects shows a good potential to improve the overall environmental performance of this UWS.
- 6.3** Zaragoza will still reduce its fresh water withdrawal via infrastructure upgrading. However, further reduction requires additional measures. The ongoing strategy of optimizing water for landscaping won't be very significant. Presently domestic consumption is already low, therefore Industrial water recycling is proposed as a suitable alternative. From this strategy also a slightly positive effect is expected on energy consumption, CO₂ emissions. No effect is expected on pollution loads to the Ebro River neither to agriculture soil.
- 6.4** Ground water is a major component of Zaragoza urban water cycle. Due to its origin on agriculture irrigation and also due to industrial pollution of soil in the past, groundwater is subjected to important threats of both quantity and quality. Zaragoza municipality and catchment authority should plan together the adequate use of this resource.
- 6.5** During the time period of the present study (last six years) the consumption of energy and chemical products, as well as the pollution loads to the Ebro River and the atmospheric emissions have remained more or less constant. Optimizing the urban water system to reduce such environmental impacts should be expressively included within the goals for water management.
- 6.6** Zaragoza has committed to the Aalborg summit for sustainable European cities, and it has set a sustainability vision. However it still requires adjusting such goals to be Specific, Measurable, Acceptable, Realistic and Time bound.

Otherwise it won't be possible to monitor the trends of the system towards sustainability.

- 6.7** Priorities for urban water sustainability would be: 1) continuing on reducing water withdrawal and unaccounted for water, 2) optimizing energy consumption and its indirect impacts on atmospheric emissions 3) reducing phosphorus loads to the Ebro. The impact of heavy metals and other persistent pollutants also deserves attention since such impact is not necessarily linear to the scale of loads. Storm water does not seem to be a major problem for Zaragoza, but the results presented here are not reliable enough. Further studies concerning this matter are required.
- 6.8** Major drivers for water management in Zaragoza are population increase, National Policies on water and environment and climate change. Combined effects are expected to worsen problems of water management for Zaragoza in the future.
- 6.9** Water from the new source, the Yesa reservoir will be able to fulfill Zaragoza's water requirements during the next 50 years, even under worst possible scenario for climate change and irrigation. However in the future might experience some negative changes on water quality. Ebro River will be even more unsuitable for drinking purposes. Therefore Zaragoza will have to completely relay on the Yesa reservoir to fulfill its water demand.
- 6.10** Comprehensive strategies to cope with such problems are to be set by all important stakeholders in Zaragoza and the SWITCH project would contribute with important initiatives to the process. The parameters presented here as sustainability indicators will contribute to assess the success of the set strategies.

7 References

ASCE (1998), Sustainability Criteria for Water Resource Systems, prepared by Task Committee on Sustainability Criteria, Water Resource Planning and Management Division, ASCE and Working Group UNESCO,/IHP IV Project M-4.3.

Ahlman S. (2006), Modeling substance Flows in Urban Drainage Systems. Thesis for the degree of Doctor of Philosophy. Chalmers University of Technology. Goteborg.

Assimacopoulos. D. (2007), Developing Long-term Vision and Scenarios for the Democities. The Example of Alexandria. SWICTH Annual meeting. Birmingham, 11th January.

Ayala-Carcedo, F.J. e Iglesias, A. (2000). Impactos del posible Cambio Climático sobre los recursos hídricos, el diseño y la planificación hidrológica en la España Peninsular. In Balairón edit., El Cambio Climático, El Campo de las Ciencias y las Artes, Servicio de Estudios del BBVA, Madrid, 201-222.

Ayers R. U and Ayers L.W. (2002), A handbook of industrial ecology. Edward Elgar Publishing Limited. Cheltenham, UK.

Benedetti L., Blumensaat F., G. Bonisch., Dirclxx G., Jardin N., Krebs P. and Vanrolleghem P.A. (2005), Systems Analysis of Urban wastewater systems – two systematic approaches to analyze a complex system. Water Science and technology. 52(12): 171-179.

Bengtsson, M, Lundin, M and Molander, S, 1997, Life Cycle Assessment of Wastewater Systems – Case studies of Conventional Wastewater Treatment, Urine Sorting and Liquid Composting in Three Swedish Municipalities, Technical Environmental Planning, Report 1997:9, Göteborg, Sweden.

CHE. (2007), Ebro River Hydrographic Confederation web site. <http://www.chebro.es>, 26/03/2007

Ebro-Agua Working group. Institute of Applied Geosciences, Darmstadt University of Technology. Department of Geography and Spatial Management, University of Zaragoza. <http://www.unizar.es/EbroAguaWorkingGroup/index.html>, 23/03/2007

European Commission (1995). ExternE, Externalities of Energy. Vol.1: Summary. Directorate-General XXII. Science, Research and Development. L-2920 Luxemburg. (available on line at <http://www.externe.info>)

Hellstrom D., Hjerpe., van Moeffaert D. (2004), Indicators to assess ecological sustainability of the Urban Water Sector. Urban Water Report Series. Report 204:3. Chalmers University of Technology. Goteborg.

Infrastructure Department, Urban Water Cycle Office of Zaragoza (2006). Informe Plan de mejora en la gestion del abastecimiento de agua en Zaragoza.

Jeppsson U. and Hellstrom D. (2002), Systems Analysis for environmental assessment of urban water and wastewater systems. Water Science and technology. 46 (6-7): 121-129

Krantz H. (2005). A Study of household routines in a process of changing water and sanitation arrangements. Linköping Studies in Arts and Science. 316. Department of Water and Environmental Studies. Linköping University, Sweden (available on line at: <http://www.urbanwater.org>), 18/03/2007

Larsen T.A. and Gujer W. (1997), The concept of sustainable Urban Management. *Water Science and technology*. 35(9): 3-10

Lassaux S., Renzoni R., and Germain A. (2005), Life Cycle Assessment of Water: From the Pumping Station to the Wastewater Treatment Plant. *International Journal on LCA*. 1: 1 -9.

Levlin. E (2005). Sustainable and Integrated sewage and organic waste handling with global warming impact. In *Integration and optimization of urban sanitation systems*. Report n 11. Royal Institute of Technology in Stockholm. (Available on line at: <http://www.lwr.kth.se>), 12/03/2007

Lindqvist A. and von Malmborg F. (2004), What can we learn from local substance flow analyses? The review of cadmium flows in Swedish municipalities. *Journal of Cleaner Production*. 12: 909-918.

Local Agenda 21 Office of Zaragoza (2002). *Auditoria de gestión y uso del agua en Zaragoza*.

Lundie S., Peters G. and Beavis P. (2004), Life cycle assessment for Sustainable Metropolitan Water Systems Planning. *Water Science and technology*. 38: 3465-3473.

Lundin M. (1999), Assessment of the environmental Sustainability of Urban Water Systems. Department of Technical Environmental Planning. Chalmers University of Technology. Goteborg.

Lundin M. and Morrison G.M. (2002). A life cycle assessment based procedure for development of environmental sustainability indicators for urban water systems. *Urban Water* 4(2):145-152

Malmqvist P. A. and Palmquist H. (2005), Decision support tools for urban and wastewater systems – focusing on hazardous flows assessment. *Water Science and technology*. 51(8): 41-49

MAPA (2007), Plan Nacional de Regadíos. Ministerio de Agricultura Pesca y Alimentación de España. (available at <http://www.mapa.es/es/desarrollo/pags/pnr/principal.htm>), 20/03/2007

Marti O. (2000). When the rain in Spain is not enough. *UNESCO courier*. December 2000 (available on line at: http://www.unesco.org/courier/2000_12/uk/planet.htm), 04/02/2007

Matsushita, R, Sudoh, O, Nakane K, Hidenari, Y, Nakayama, S, and Ishitani H, 1997, Life Cycle Assessment of Sewage Treatment Technologies, Presented at IAWQ Conference on "Sludge - Waste or Resource?" held in Czestochowa, Poland 26-28 June.

Mema. M., Calvo E., and Albiac J. (2006), Agricultural nonpoint pollution in Aragon: emission loads and control issues. Final Report. Spanish Ministry of Education and Science. Projects CICYT AGL2001-2333-C02 and RTA04-141-C2.

Ministerio de Industria, Turismo y Comercio de España (2007), Plan Energetico Nacional. (available at <http://www.mityc.es/Desarrollo/Seccion/IDI/PlanesNacionales/>), 20/03/2007

Neumayr, R, Dietrich, R and Steinmüller, H, 1997, Life Cycle Assessment of Sewage Sludge Treatment, Proc 5th SETAC Annual Conference, Brussels, December.

Roeleveld, P J, Klapwijk A, Eggels, P G, Rulkens, W H, and Starckenburg, W van, 1997, Sustainability of Municipal Wastewater Treatment, Water Science and Technology 35(10), 221-228.

Thonstad E. (2005). Environmental Impacts of Intermodal freight transport. Report no. 0513. Molde University College (available on line at: <http://mfm.no>), 12/02/2007

U.S. EPA. (2006), Life Cycle Assessment: Principles and Practice. National Risk Management Research Laboratory. Cincinnati, Ohio. Document reference 600/R-06/060. Available on-line at <http://www.epa.gov>

UNCCD (2007), United Nations Convention to Combat Desertification. Regional Profiles. <http://www.unccd.int>, 20/03/2007

UNESCO (1999), Working Group M.I.V. Sustainability Criteria for Water Resource Systems. Cambridge, UK: Cambridge University Press

Varis O. and Somlyódy L. (1997), Global urbanization and Urban Water: Can sustainability be afforded?. Water Science and technology. 35(9): 21-32

Annexes

Annex 1.
Inventory for data necessary to perform LCA and its availability in Zaragoza

Process	Availability	Frequency	Data type	Aggregation level
1 Inputs				
1.1 Surface water withdrawal				
1.1.1 Energy				
1.1.1.1 Consumption	2000 – 2006	Monthly	Measured	Individual
1.1.1.2 Energy sources	No data			
1.1.2 Inflow water				
1.2 Groundwater extraction				
1.2.1 Energy				
1.2.1.1 Energy consumption	2000	Sporadic	Measured	From one well and extrapolated to the whole system
1.2.1.2 Energy sources	No data			
1.2.2 Water				
1.2.2.1 Flow	2003 – 2006	Trimester	Measured	Composite
1.3 Storm water				
1.3.1 Precipitation	2000 – 2006	Daily	Measured	Composite
1.3.2 N	No data			
1.3.3 P	No data			
1.3.4 Heavy metal concentration	No data			
1.3.5 Persistent Organics	No data			
2 Drinking water treatment				
2.1 Energy				
2.1.1 Energy consumption	2000 – 2006	Monthly	Measured	Individual
2.1.2 Energy sources	No data			
2.2 Water				
2.2.1 Inflow	2000 – 2006	Daily	Measured	Individual
2.2.2 Outflow	2000 – 2006	Daily	Measured	Individual
2.3 Chemical products consumption				
2.3.1 Alum	2000 – 2006	Monthly	Measured	Individual
2.3.2 Powdered Activated Carbon	2000 – 2006	Monthly	Measured	Individual
2.3.3 Chlorine	2000 – 2006	Monthly	Measured	Individual
2.4 Sludge production	2000 – 2006	Monthly	Measured	Individual
3 Distribution system				
3.1 Energy				
3.1.1 Energy consumption	2002 – 2006	Trimester	Measured	Composite Dist Netwrk
3.1.2 Energy sources	No data			

3.2	Water				
3.2.1	Flows	No data			
3.2.2	Leakage	No data			
4	Water consumption				
4.1	Household	2000 – 2006	Trimester	Measured	Composite
4.2	Public Facilities	2003 – 2006	Trimester	Measured	Composite and incomplete*
4.3	Landscaping				
4.3.1	Tap water consumption	2003 – 2006	Trimester	Measured	Composite and incomplete*
4.3.2	Groundwater consumption	2003 – 2006	Trimester	Measured	Composite and incomplete*
4.4	Industry				
4.4.1	Connected to sewers				
4.4.1.1	Tap water	2002 – 2006	Trimester	Measured	Individual
4.4.1.2	Groundwater	2002 – 2006	Trimester	Measured	Individual
4.4.2	No connected to sewers**	2000, 2000, 2003	Sporadic	Estimated	Individual
4.4.2.1	Tap water	No consumption			
4.4.2.2	Groundwater	1995, 2000, 2003	Annual	Estimated	Average
5	Sewer system				
5.1	Industrial				
5.1.1	Flow	2005, 2006	Annual	Measured	Composite***
5.1.2	N	2005, 2006	Annual	Measured	Composite***
5.1.3	P	2005, 2006	Annual	Measured	Composite***
5.1.4	Heavy metals	2005, 2006	Annual	Measured	Composite***
5.2	Household				
5.2.1	Flow	No data			
5.2.2	N	No data			
5.2.3	P	No data			
5.2.4	Heavy metals	No data			
5.3	Storm water				
5.3.1	Flow	No data			
5.3.2	N	No data			
5.3.3	P	No data			
5.3.4	Heavy metals	No data			
6	Wastewater treatment				
6.1	“La Cartuja” (tertiary treatment)				
6.1.1	Energy				
6.1.1.1	Energy consumption	2000 – 2006	Monthly	Measured	Individual
6.1.1.2	Energy Production	2000 – 2006	Monthly	Measured	Individual
6.1.1.3	Energy sources	No data			

6.1.2	Water					
6.1.2.1	Inflow					
6.1.2.1.1	Flow	2000 – 2006	Daily	Measured	Individual	
6.1.2.1.2	N	1997 – 2006	Daily	Measured	Individual	
6.1.2.1.3	P	2001 – 2006	Daily	Measured	Individual	
6.1.2.1.4	BOD ₅	2001 – 2006	Daily	Measured	Individual	
6.1.2.1.5	COD	2001 – 2006	Daily	Measured	Individual	
6.1.2.1.6	Heavy metals	2000, 2003, 2005	Sporadic	Measured	Average	
6.1.2.2	Outflow					
6.1.2.2.1	Flow	2001 – 2006	Daily	Measured	Individual	
6.1.2.2.2	N	2001 – 2006	Daily	Measured	Individual	
6.1.2.2.3	P	2001 – 2006	Daily	Measured	Individual	
6.1.2.2.4	BOD ₅	2001 – 2006	Daily	Measured	Individual	
6.1.2.2.5	COD	2001 – 2006	Daily	Measured	Individual	
6.1.2.2.6	Heavy metals	2000, 2003	Sporadic	Measured	Average	
6.1.3	Iron Chloride consumption	2001 – 2006	Daily	Measured	Individual	
6.1.4	Sludge****					
6.1.4.1	Production	2001 – 2006	Daily	Measured	Individual	
6.1.4.2	N	2000, 2003, 2005	Sporadic	Measured	Average	
6.1.4.3	P	2000, 2003, 2005	Sporadic	Measured	Average	
6.1.4.4	Heavy metals	2000, 2003, 2005	Sporadic	Measured	Average	
6.1.5	Atmospheric emissions					
6.1.5.1	Flow	2000, 2003, 2005	Sporadic	Measured	Average	
6.1.5.2	CO ₂	2000, 2003, 2005	Sporadic	Measured	Average	
6.1.5.3	NO _x	2000, 2003, 2005	Sporadic	Measured	Average	
6.1.5.4	Heavy metals	2000, 2003, 2005	Sporadic	Measured	Average	
6.2	“La Almozara” (Conventional treat)					
6.2.1	Energy					
6.2.1.1	Energy consumption	2001 – 2006	Monthly	Measured	Individual	
6.2.1.2	Energy Production	2001 – 2006	Monthly	Measured	Individual	
6.2.1.3	Energy sources	No data				
6.2.2	Water					
6.2.2.1	Inflow					
6.2.2.1.1	Flow	2001 – 2006	Daily	Measured	Individual	
6.2.2.1.2	N	2000, 2003, 2005	Sporadic	Measured	Average	
6.2.2.1.3	P	2000, 2003, 2005	Sporadic	Measured	Average	
6.2.2.1.4	BOD ₅	2001 – 2006	Daily	Measured	Individual	
6.2.2.1.5	COD	2001 – 2006	Daily	Measured	Individual	
6.2.2.1.6	Heavy metals	2000, 2003, 2005	Sporadic	Measured	Average	

6.2.2.2 Outflow					
6.2.2.2.1	Flow	2001 – 2006	Daily	Measured	Individual
6.2.2.2.2	N	2000, 2003, 2005	Sporadic	Measured	Average
6.2.2.2.3	P	2000, 2003, 2005	Sporadic	Measured	Average
6.2.2.2.4	BOD ₅	2001 – 2006	Daily	Measured	Individual
6.2.2.2.5	COD	2001 – 2006	Daily	Measured	Individual
6.2.2.2.6	Heavy metals	2000, 2003, 2005	Sporadic	Measured	Average
6.2.3 Sludge					
6.2.3.1	Production	2001 – 2006	Daily	Measured	Individual
6.2.3.2	N	2000, 2003, 2005	Sporadic	Measured	Average
6.2.3.3	P	2000, 2003, 2005	Sporadic	Measured	Average
6.2.3.4	Heavy metals	2000, 2003, 2005	Sporadic	Measured	Average
6.3 Paper mills					
6.3.1 Inflow					
6.3.1.1	Flow	2005	Sporadic	Measured	Average
6.3.1.2	N	2005	Sporadic	Measured	Average
6.3.1.3	P	2005	Sporadic	Measured	Average
6.3.1.4	Heavy metals	2005	Sporadic	Measured	Average
6.3.2 Outflow					
6.3.2.1	Flow	2005	Sporadic	Measured	Average
6.3.2.2	N	2005	Sporadic	Measured	Average
6.3.2.3	P	2005	Sporadic	Measured	Average
6.3.2.4	Heavy metals	2005	Sporadic	Measured	Average

Annex 2
Raw Data for the Drinking Water Treatment Plant of Zaragoza on monthly basis

Year	Month	Water Inflow (m3)	Water Outflow (m3)	Electricity consumption (kW/h)	Chlorine (ton)	Alum (ton)	PAC (ton)	Sludge as Dry matter (ton)
2000	Jan	6,770,097	6,606,332	422,389	129	493		
2000	Feb	6,173,221	6,053,436	424,006	231	539		
2000	Mar	6,434,724	6,242,472	423,525	206	873		
2000	Apr	5,914,356	5,573,862	422,125	207	748		
2000	May	6,644,068	6,141,830	425,700	254	954		
2000	Jun	7,108,234	227,622	424,344	305	946		
2000	Jul	7,275,509	6,624,409	430,381	441	697		
2000	Aug	6,826,737	6,376,162	413,254	418	815		
2000	Sep	6,835,202	6,570,241	412,545	418	820		
2000	Oct	6,549,294	5,311,733	392,909	289	750		
2000	Nov	6,216,782	5,412,375	400,145	130	760		
2000	Dec	6,605,970	5,012,027	428,945	182	508		
2001	Jan	6,526,381	6,252,197	406,363	131	515		
2001	Feb	5,858,885	5,620,512	422,539	102	546		
2001	Mar	6,352,281	6,015,076	445,242	234	639		
2001	Apr	6,054,660	5,789,890	392,909	289	750		
2001	May	6,450,521	6,082,503	453,096	102	664		
2001	Jun	7,166,591	6,721,492	451,972	466	816		
2001	Jul	7,066,998	6,637,223	449,333	467	853		
2001	Aug	6,874,706	6,465,713	412,272	365	954		
2001	Sep	6,786,170	6,389,769	404,713	469	873		
2001	Oct	6,735,425	6,332,661	408,636	491	1,144		
2001	Nov	6,562,416	6,228,397	407,091	181	1,116		
2001	Dec	6,902,742	6,637,920	414,498	68	1,175		
2002	Jan	6,671,771	6,336,940	425,772	219	961		
2002	Feb	5,689,575	5,545,301	416,763	126	816		
2002	Mar	6,234,004	5,965,224	428,447	126	689		
2002	Apr	5,761,476	5,661,557	435,805	151	83		
2002	May	6,097,677	6,035,169	436,828	301	786		
2002	Jun	6,508,874	6,412,899	441,668	289	750		454
2002	Jul	6,669,855	6,564,184	429,573	529	1,156		366
2002	Aug	6,093,249	6,000,995	418,739	375	658		612
2002	Sep	6,199,178	6,169,763	408,178	329	824		777
2002	Oct	6,231,246	6,150,255	408,734	303	875		677
2002	Nov	6,173,832	6,121,811	413,999	126	852		373

Year	Month	Water Inflow (m3)	Water Outflow (m3)	Electricity consumption (kW/h)	Chlorine (ton)	Alum (ton)	PAC (ton)	Sludge as Dry matter (ton)
2002	Dec	6,134,871	6,012,239	416,031	100	640		230
2003	Jan	6,089,380	6,028,486	421,370	148	557		252
2003	Feb	5,371,790	5,318,072	426,697	74	679		484
2003	Mar	5,693,297	5,636,364	429,461	150	710		555
2003	Apr	5,387,239	5,333,367	435,687	175	600		372
2003	May	5,932,808	5,873,480	435,968	327	712		708
2003	Jun	6,339,409	6,276,015	331,702	476	874		791
2003	Jul	6,549,021	6,483,531	424,539	377	986		811
2003	Aug	6,313,334	6,250,201	416,306	401	863		510
2003	Sep	6,041,265	5,980,852	512,727	328	914		903
2003	Oct	6,144,342	6,082,899	539,999	278	733	18	693
2003	Nov	5,822,186	5,763,964	501,818	100	740	27	920
2003	Dec	5,999,298	5,939,305	558,181	75	964	0	596
2004	Jan	5,634,038	5,577,698	530,909	174	495	0	482
2004	Feb	5,270,245	5,217,543	476,363	149	354	0	151
2004	Mar	5,848,789	5,790,301	519,999	220	547	0	331
2004	Apr	5,451,585	5,397,069	492,727	224	465	0	504
2004	May	5,936,482	5,877,117	521,818	273	789	0	452
2004	Jun	6,520,613	6,455,407	576,363	372	1,110	0	546
2004	Jul	6,416,490	6,352,325	570,909	368	1,137	22	733
2004	Aug	5,912,750	5,853,623	567,272	397	899	58	605
2004	Sep	6,171,743	6,110,026	570,909	325	1,118	43	733
2004	Oct	6,047,407	5,986,933	607,272	223	982	58	645
2004	Nov	5,827,125	5,768,854	534,545	274	1,159	29	478
2004	Dec	5,796,132	5,738,171	543,636	75	785	128	336
2005	Jan	5,921,724	5,862,507	634,040	126	596	0	366
2005	Feb	5,505,974	5,450,914	578,600	126	515	0	277
2005	Mar	5,860,462	5,801,857	573,528	148	299	0	165
2005	Apr	5,601,426	5,545,412	572,869	149	299	0	343
2005	May	5,771,352	5,713,638	602,325	201	272	0	703
2005	Jun	5,960,140	5,900,539	609,514	245	517	0	747
2005	Jul	6,017,296	5,957,123	607,388	247	488	2	482
2005	Aug	5,463,150	5,408,519	580,835	268	1,135	29	752
2005	Sep	5,645,151	5,588,699	567,770	226	1,032	29	671
2005	Oct	5,404,662	5,350,615	595,041	224	1,135	59	579
2005	Nov	5,261,737	5,209,120	578,447	151	380	30	531
2005	Dec	5,772,795	5,715,067	515,920	126	859	30	358
2006	Jan	5,768,970	5,711,280	669,661	156	325	0	411
2006	Feb	4,772,922	4,725,193	489,938	128	216	0	172
2006	Mar	5,227,862	5,175,583	554,199	129	298	0	464
2006	Apr	4,855,018	4,806,468	448,916	153	297	0	474
2006	May	5,620,081	5,563,880	576,937	206	432	0	722
2006	Jun	5,856,470	5,797,905	579,142	305	460	36	714
2006	Jul	5,870,798	5,812,090	619,655	279	807	0	927
2006	Aug	5,266,321	5,213,658	569,217	282	644	15	709
2006	Sep	5,473,739	5,419,002	586,965	256	453	33	1,003
2006	Oct	5,331,003	5,277,693	549,326	207	896	32	1,028
2006	Nov	4,918,971	4,869,781	517,497	154	311	24	458
2006	Dec	5,187,183	5,135,312	580,419	200	849	39	594

Annex 3
Raw Data for Energy Consumption of the Water Distribution Network in Zaragoza

Year	Month	Energy consumption (Kwh)	Year	Month	Energy consumption (Kwh)	Year	Month	Energy consumption (Kwh)
2001	jan	81,273	2003	jan	63,206	2005	jan	56,364
2001	feb	84,508	2003	feb	64,005	2005	feb	51,455
2001	mar	89,048	2003	mar	64,419	2005	mar	51,273
2001	apr	78,582	2003	apr	65,353	2005	apr	51,091
2001	may	90,619	2003	may	65,395	2005	may	53,311
2001	jun	90,394	2003	jun	49,755	2005	jun	54,144
2001	jul	89,867	2003	jul	63,681	2005	jul	54,182
2001	aug	82,454	2003	aug	62,446	2005	aug	50,909
2001	sep	80,943	2003	sep	76,909	2005	sep	50,182
2001	oct	81,727	2003	oct	81,000	2005	oct	51,636
2001	nov	81,418	2003	nov	75,273	2005	nov	50,364
2001	dec	82,900	2003	dec	83,727	2005	dec	45,636
2002	jan	76,639	2004	jan	53,091	2006	jan	60,727
2002	feb	75,017	2004	feb	47,636	2006	feb	44,364
2002	mar	77,120	2004	mar	52,000	2006	mar	48,727
2002	apr	78,445	2004	apr	49,273	2006	apr	43,818
2002	may	78,629	2004	may	52,182	2006	may	50,727
2002	jun	79,500	2004	Jun	57,636	2006	jun	51,091
2002	jul	77,323	2004	Jul	57,091	2006	jul	54,000
2002	aug	75,373	2004	Aug	56,727	2006	aug	49,455
2002	sep	73,472	2004	Sep	57,091	2006	sep	51,636
2002	oct	73,572	2004	Oct	60,727	2006	oct	48,398
2002	nov	74,520	2004	Nov	53,455	2006	nov	46,909
2002	dec	74,886	2004	Dec	54,364	2006	dec	50,727

Annex 4
Groundwater flows and energy consumed for groundwater extraction

Energy consumption has been extrapolated from the following assumptions:

- Average groundwater table depth in Zaragoza = 5m
(Personal communication, Local agenda 21 Office)
- Average energy consumption for groundwater extraction
= 0.02 Kwh/m³ at 5m height
(Personal communication, Local agenda 21 Office)

Year	Water extraction (m ³)				Energy consumption (Kwh)			
	Industries connected to the sewer system	Landscaping	Paper mills	Total groundwater extraction	Industries connected to the sewer system	Landscaping	Paper mills	Total groundwater extraction
2001	1,369,411	1,462,301	16,000,000	18,831,712	27,388	29,246	320,000	376,634
2002	1,566,324			19,028,625	31,326			380,573
2003	1,457,208			18,919,509	29,144			378,390
2004	1,568,466			19,030,767	31,369			380,615
2005	1,309,231			18,771,532	26,185			375,431
2006	1,481,114			18,943,415	29,622			378,868

Annex 5
Raw Data for "Cartuja" WWTP

year	month	Inflow (m ³)	BOD in (ton)	COD in (ton)	TP in (ton)	TN in (ton)	FeCl3 (ton)	BOD out (ton)	COD out (ton)	TP out (ton)	TN out (ton)	TP sludge (ton)	TN to the atmosphere as NOx (ton)	TN sludge (ton)	Sludge as ash (ton)
2001	jan	4,403,500	1,442	3,252	42	183	439	60	269	6	89	36	1.90	92	455
2001	feb	3,959,200	1,184	2,793	38	166	398	51	240	6	81	33		83	413
2001	mar	4,183,100	1,169	2,653	38	172	420	34	214	6	85	32		86	354
2001	apr	4,966,700	1,205	2,842	44	198	390	61	299	7	97	36		98	386
2001	may	5,452,700	1,293	3,065	50	208	480	57	279	8	103	43		103	457
2001	jun	5,499,800	1,350	3,268	51	201	477	78	327	8	99	44		100	398
2001	jul	5,634,700	1,286	3,117	45	201	427	58	298	7	99	38		100	383
2001	aug	5,319,000	1,012	2,520	43	180	412	56	262	7	90	37		89	307
2001	sep	4,907,500	1,124	2,766	43	170	410	62	261	7	84	36		84	422
2001	oct	5,204,400	1,260	2,962	46	195	425	61	300	7	96	40		97	513
2001	nov	4,641,200	1,247	3,226	43	185	376	66	291	7	91	37		93	360
2001	dec	4,542,600	1,332	3,274	44	187	411	54	274	7	92	37		93	307
2002	jan	4,602,000	1,419	3,317	42	186	419	54	281	7	91	36		94	400
2002	feb	4,301,120	1,224	2,879	41	176	370	53	263	6	85	34		89	299
2002	mar	4,798,200	1,300	3,024	43	186	411	58	275	7	91	36		93	391
2002	apr	4,729,700	1,287	3,010	45	183	420	68	287	7	90	38		92	414
2002	may	5,111,600	1,321	3,075	49	195	500	91	333	7	96	43		98	438
2002	jun	4,770,400	1,341	3,260	45	184	425	75	314	7	91	38		92	389
2002	jul	4,834,300	1,186	2,830	43	179	408	46	248	7	88	36		89	449
2002	aug	4,531,100	1,088	2,492	38	156	375	37	203	6	77	32		77	346
2002	sep	4,929,900	1,272	2,992	40	192	275	68	265	6	96	34		95	356
2002	oct	5,032,400	1,477	3,472	45	199	410	94	346	7	98	38		99	395
2002	nov	5,027,900	1,609	3,789	45	204	402	104	370	7	100	38		102	361
2002	dec	4,328,100	1,368	3,288	43	174	426	78	285	6	85	37		86	403

year	month	Inflow (m ³)	BOD in (ton)	COD in (ton)	TP in (ton)	TN in (ton)	FeCl ₃ (ton)	BOD out (ton)	COD out (ton)	TP out (ton)	TN out (ton)	TP sludge (ton)	TN to the atmosphere as NO _x (ton)	TN sludge (ton)	Sludge as ash (ton)
2003	jan	4,761,500	1,576	3,754	43	190	426	108	364	7	94	36	2.05	94	382
2003	feb	2,435,300	1,221	2,945	36	146	120	78	285	5	48	30		96	132
2003	mar	4,918,700	1,292	3,050	45	189	408	96	362	7	92	38		94	305
2003	apr	5,655,600	1,297	3,032	44	202	410	95	351	8	101	37		99	457
2003	may	5,288,600	1,303	3,121	40	189	385	93	348	7	95	34		92	544
2003	jun	5,372,300	1,217	2,931	47	186	399	104	369	8	93	40		91	449
2003	jul	5,232,400	1,142	2,824	48	180	452	95	330	7	90	40		88	410
2003	aug	4,992,800	963	2,320	42	163	405	37	235	7	82	35		79	392
2003	sep	5,445,400	1,186	2,896	42	185	409	41	240	7	92	35		90	557
2003	oct	5,560,600	1,278	3,193	46	205	428	97	262	7	102	39		100	481
2003	nov	4,914,400	1,242	3,012	47	192	430	43	219	7	96	40		94	547
2003	dec	4,790,800	1,243	3,028	43	193	419	66	280	7	96	37		95	457
2004	jan	3,782,200	1,046	2,590	38	172	379	51	224	6	84	32		86	241
2004	feb	4,299,600	1,210	2,728	38	183	360	60	265	6	90	33		91	292
2004	mar	3,935,100	1,308	2,959	36	181	357	49	213	5	88	31		91	311
2004	apr	4,753,500	1,230	2,733	43	198	412	74	288	7	97	36		99	290
2004	may	4,501,400	1,269	2,813	40	187	372	67	280	6	92	33		93	286
2004	jun	5,730,100	1,326	2,930	47	218	435	101	377	7	108	40		107	297
2004	jul	5,409,100	1,225	2,806	44	200	399	53	274	7	99	37		99	317
2004	aug	4,905,300	1,031	2,456	38	175	360	50	251	6	87	32		87	283
2004	sep	4,786,600	1,254	2,884	38	189	356	64	270	6	93	32		94	405
2004	oct	5,453,500	1,432	3,273	46	215	417	89	366	7	107	38		106	333
2004	nov	4,529,400	1,347	3,148	42	193	423	97	344	7	96	36		95	347
2004	dec	4,753,600	1,415	3,379	42	202	412	95	348	6	101	35		99	296

year	month	Inflow (m ³)	BOD in (ton)	COD in (ton)	TP in (ton)	TN in (ton)	FeCl3 (ton)	BOD out (ton)	COD out (ton)	TP out (ton)	TN out (ton)	TP sludge (ton)	TN to the atmosphere as NOx (ton)	TN sludge (ton)	Sludge as ash (ton)
2005	jan	4,570,700	1,430	3,465	41	210	410	92	345	6	105	34	1.80	103	271
2005	feb	4,402,000	1,574	3,266	42	198	414	88	356	7	99	35		97	328
2005	mar	4,969,500	1,663	3,572	44	214	415	101	395	7	108	37		104	347
2005	apr	5,303,500	1,655	3,599	46	223	461	84	378	7	113	39		108	362
2005	may	5,707,300	1,772	4,000	52	229	490	121	434	9	117	44		111	371
2005	jun	5,585,000	1,577	3,520	46	228	426	81	387	8	116	39		110	405
2005	jul	5,198,800	1,484	3,198	46	218	435	51	319	8	110	38		106	338
2005	aug	4,884,200	1,259	2,858	42	195	375	38	239	7	100	35		94	344
2005	sep	5,470,100	1,413	3,143	46	224	426	44	297	8	114	38		108	388
2005	oct	4,967,000	1,551	3,276	45	215	435	51	285	7	109	37		104	363
2005	nov	4,479,100	1,375	2,900	40	199	390	56	276	6	100	34		97	281
2005	dec	4,294,600	1,407	3,001	38	193	365	56	258	6	96	32		94	249
2006	jan	4,287,060	1,536	2,955	38	191	373	41	227	6	96	32		93	336
2006	feb	3,370,800	1,228	2,696	34	182	357	57	272	5	92	29		88	338
2006	mar	3,460,400	1,192	2,521	35	189	332	63	243	6	90	29		97	175
2006	apr	4,393,600	1,421	3,320	44	207	412	87	312	7	104	37		101	303
2006	may	5,045,900	1,707	3,756	49	236	464	127	391	8	120	41		114	323
2006	jun	5,281,500	1,609	3,497	47	217	455	87	276	7	110	40		105	361
2006	jul	4,575,600	1,225	2,666	40	169	345	34	212	6	85	34		82	426
2006	aug	4,193,600	1,098	2,467	33	159	309	36	195	5	81	28		77	278
2006	sep	5,327,500	1,443	3,092	44	196	401	40	237	7	99	37		95	475
2006	oct	5,541,500	1,798	3,781	47	243	451	53	297	8	122	40		118	339
2006	nov	5,163,700	1,620	3,437	46	219	426	46	267	7	111	38		107	407
2006	dec	3,741,600	1,709	3,609	46	231	438	50	282	8	116	39		113	373

Energy consumption and production (Kwh)											
Year	Month	Consumed	Produced	Year	Month	Consumed	Produced	Year	Month	Consumed	Produced
2001	Jan	2,227,010	122,670	2003	Jan	2,411,570	78,040	2005	Jan	2,487,884	239,280
2001	Feb	2,090,040	121,300	2003	Feb	1,422,640	22,730	2005	Feb	2,232,800	251,110
2001	Mar	2,214,650	132,910	2003	Mar	2,198,220	281,060	2005	Mar	2,367,990	259,640
2001	Apr	2,288,800	229,590	2003	Apr	2,409,870	204,120	2005	Apr	2,460,130	175,240
2001	May	2,442,650	284,950	2003	May	2,493,660	232,820	2005	May	2,671,180	163,380
2001	Jun	2,547,160	248,400	2003	Jun	2,439,510	476,850	2005	Jun	2,588,190	182,780
2001	Jul	2,446,140	153,420	2003	Jul	2,587,670	519,480	2005	Jul	2,525,970	181,990
2001	Aug	2,236,080	176,400	2003	Aug	2,472,360	438,740	2005	Aug	2,299,730	140,000
2001	Sep	2,309,410	227,850	2003	Sep	2,480,480	165,710	2005	Sep	2,501,490	127,560
2001	Oct	2,541,570	272,370	2003	Oct	2,634,590	127,350	2005	Oct	2,499,150	116,730
2001	Nov	2,410,120	209,350	2003	Nov	2,546,550	130,240	2005	Nov	2,408,790	121,330
2001	Dec	2,491,630	179,840	2003	Dec	2,586,830	139,270	2005	Dec	2,288,237	140,130
2002	Jan	2,500,211	229,037	2004	Jan	2,472,190	55,800	2006	Jan	2,316,915	118,920
2002	Feb	2,116,740	138,630	2004	Feb	2,334,170	77,800	2006	Feb	2,083,962	110,180
2002	Mar	2,448,870	150,020	2004	Mar	2,260,280	52,350	2006	Mar	2,200,117	50,000
2002	Apr	2,442,460	79,410	2004	Apr	2,358,720	139,770	2006	Apr	2,386,256	65,437
2002	May	2,502,730	143,960	2004	May	2,413,670	76,690	2006	May	2,506,871	98,621
2002	Jun	2,467,240	113,660	2004	Jun	2,560,730	168,730	2006	Jun	2,506,648	119,209
2002	Jul	2,441,790	126,410	2004	Jul	2,542,780	179,140	2006	Jul	2,572,370	126,710
2002	Aug	2,284,350	38,190	2004	Aug	2,347,320	91,890	2006	Aug	2,274,580	73,390
2002	Sep	2,231,450	51,890	2004	Sep	2,336,470	226,420	2006	Sep	2,443,220	192,220
2002	Oct	2,516,780	75,930	2004	Oct	2,590,310	245,450	2006	Oct	2,608,917	188,770
2002	Nov	2,411,860	65,170	2004	Nov	2,321,780	212,760	2006	Nov	2,526,068	190,495
2002	Dec	2,323,540	194,820	2004	Dec	2,487,874	226,550	2006	Dec	2,567,493	189,633

Annex 6
Raw Data for "Almozara" WWTP

Year	Month	Inflow (m ³)	Energy consumption (Kwh)	Energy production (Kwh)	BOD in (ton)	Sludge (ton)	COD in (ton)	TP in (ton)	TN in (ton)	BOD out (ton)	COD out (ton)	TP out (ton)	TN out (ton)	TP sludge (ton)	TN sludge (ton)
2001	jan	880,154	199,643	0	185	86	431	6.2	30.8	12.3	49.3	4.4	16.9	1.8	7.7
2001	feb	791,349	175,366	0	166	78	388	5.5	27.7	11.1	44.3	4.0	15.2	1.6	6.9
2001	mar	836,101	114,882	94,500	176	82	410	5.9	29.3	11.7	46.8	4.2	16.1	1.7	7.3
2001	apr	992,724	61,961	129,800	208	97	486	6.9	34.7	13.9	55.6	5.0	19.1	2.0	8.7
2001	may	1,089,864	65,510	149,400	229	93	534	7.6	38.1	15.3	61.0	5.4	21.0	2.2	9.5
2001	jun	1,099,278	55,502	144,400	231	101	539	7.7	38.5	15.4	61.6	5.5	21.2	2.2	9.6
2001	jul	1,126,241	64,013	142,600	237	91	552	7.9	39.4	15.8	63.1	5.6	21.7	2.3	9.9
2001	aug	1,063,140	93,152	111,600	223	85	521	7.4	37.2	14.9	59.5	5.3	20.5	2.1	9.3
2001	sep	980,892	59,566	132,000	206	93	481	6.9	34.3	13.7	54.9	4.9	18.9	2.0	8.6
2001	oct	1,040,235	54,437	140,600	218	106	510	7.3	36.4	14.6	58.3	5.2	20.0	2.1	9.1
2001	nov	927,665	33,761	157,400	195	91	455	6.5	32.5	13.0	51.9	4.6	17.9	1.9	8.1
2001	dec	907,957	37,575	163,300	191	76	445	6.4	31.8	12.7	50.8	4.5	17.5	1.8	7.9
2002	jan	965,126	70,334	140,200	203	94	473	6.8	33.8	13.5	54.0	4.8	18.6	1.9	8.4
2002	feb	902,025	36,589	147,200	189	88	442	6.3	31.6	12.6	50.5	4.5	17.4	1.8	7.9
2002	mar	1,006,272	45,266	156,400	211	99	493	7.0	35.2	14.1	56.4	5.0	19.4	2.0	8.8
2002	apr	991,907	47,158	147,400	208	97	486	6.9	34.7	13.9	55.5	5.0	19.1	2.0	8.7
2002	may	1,071,998	43,152	159,800	225	105	525	7.5	37.5	15.0	60.0	5.4	20.6	2.1	9.4
2002	jun	1,000,442	68,425	137,000	210	98	490	7.0	35.0	14.0	56.0	5.0	19.3	2.0	8.8
2002	jul	1,013,843	61,906	136,000	213	99	497	7.1	35.5	14.2	56.8	5.1	19.5	2.0	8.9
2002	aug	950,257	69,007	96,900	200	81	466	6.7	33.3	13.3	53.2	4.8	18.3	1.9	8.3
2002	sep	1,033,892	81,280	107,300	217	95	507	7.2	36.2	14.5	57.9	5.2	19.9	2.1	9.0
2002	oct	1,055,389	55,911	134,600	222	85	517	7.4	36.9	14.8	59.1	5.3	20.3	2.1	9.2
2002	nov	1,054,445	50,431	137,600	221	84	517	7.4	36.9	14.8	59.0	5.3	20.3	2.1	9.2
2002	dec	907,684	41,355	153,400	191	86	445	6.4	31.8	12.7	50.8	4.5	17.5	1.8	7.9

Year	Month	Inflow (m ³)	Energy consumption	Energy production	BOD in (ton)	Sludge (ton)	COD in (ton)	TP in (ton)	TN in (ton)	BOD out (ton)	COD out (ton)	TP out (ton)	TN out (ton)	TP sludge (ton)	TN sludge (ton)
2003	jan	948,925	66,363	124,786	199	96	465	6.6	33.2	13.3	53.1	4.7	18.3	1.9	8.3
2003	feb	485,334	73,547	111,914	102	48	238	3.4	17.0	6.8	27.2	2.4	9.3	1.0	4.2
2003	mar	980,254	99,758	128,400	206	82	480	6.9	34.3	13.7	54.9	4.9	18.9	2.0	8.6
2003	apr	1,127,111	85,595	139,800	237	110	552	7.9	39.4	15.8	63.1	5.6	21.7	2.3	9.9
2003	may	1,053,971	64,046	135,100	221	103	516	7.4	36.9	14.8	59.0	5.3	20.3	2.1	9.2
2003	jun	1,070,652	66,636	126,800	225	105	525	7.5	37.5	15.0	60.0	5.4	20.6	2.1	9.4
2003	jul	1,042,771	52,572	106,700	219	102	511	7.3	36.5	14.6	58.4	5.2	20.1	2.1	9.1
2003	aug	995,021	66,868	104,000	209	98	488	7.0	34.8	13.9	55.7	5.0	19.2	2.0	8.7
2003	sep	1,085,220	42,926	121,600	228	106	532	7.6	38.0	15.2	60.8	5.4	20.9	2.2	9.5
2003	oct	1,108,179	57,714	126,900	233	108	543	7.8	38.8	15.5	62.1	5.5	21.3	2.2	9.7
2003	nov	979,397	49,285	132,200	206	83	480	6.9	34.3	13.7	54.8	4.9	18.9	2.0	8.6
2003	dec	954,764	94,797	128,600	201	88	468	6.7	33.4	13.4	53.5	4.8	18.4	1.9	8.4
2004	jan	877,727	42,926	167,300	184	71	430	6.1	30.7	12.3	49.2	4.4	16.9	1.8	7.7
2004	feb	997,799	57,714	121,100	210	79	489	7.0	34.9	14.0	55.9	5.0	19.2	2.0	8.7
2004	mar	913,210	49,285	126,900	192	87	447	6.4	32.0	12.8	51.1	4.6	17.6	1.8	8.0
2004	apr	1,103,135	94,797	68,500	232	112	541	7.7	38.6	15.4	61.8	5.5	21.2	2.2	9.7
2004	may	1,044,630	60,329	126,100	219	102	512	7.3	36.6	14.6	58.5	5.2	20.1	2.1	9.1
2004	jun	1,329,772	52,123	111,400	279	111	652	9.3	46.5	18.6	74.5	6.6	25.6	2.7	11.6
2004	jul	1,255,278	69,079	98,700	264	123	615	8.8	43.9	17.6	70.3	6.3	24.2	2.5	11.0
2004	aug	1,138,363	93,452	75,700	239	112	558	8.0	39.8	15.9	63.7	5.7	21.9	2.3	10.0
2004	sep	1,110,816	57,469	110,800	233	109	544	7.8	38.9	15.6	62.2	5.6	21.4	2.2	9.7
2004	oct	1,265,582	41,008	137,400	266	124	620	8.9	44.3	17.7	70.9	6.3	24.4	2.5	11.1
2004	nov	1,051,128	156,556	35,400	221	103	515	7.4	36.8	14.7	58.9	5.3	20.2	2.1	9.2
2004	dec	1,103,158	41,910	154,500	232	108	541	7.7	38.6	15.4	61.8	5.5	21.2	2.2	9.7

Year	Month	Inflow (m ³)	Energy consumption	Energy production	BOD in (ton)	Sludge (ton)	COD in (ton)	TP in (ton)	TN in (ton)	BOD out (ton)	COD out (ton)	TP out (ton)	TN out (ton)	TP sludge (ton)	TN sludge (ton)
2005	jan	1,059,861	48,682	162,600	223	104	519	7.4	37.1	14.8	59.4	5.3	20.4	2.1	9.3
2005	feb	1,020,743	43,290	134,000	214	100	500	7.1	35.7	14.3	57.2	5.1	19.6	2.0	8.9
2005	mar	1,152,335	50,801	165,500	242	113	565	8.1	40.3	16.1	64.5	5.8	22.2	2.3	10.1
2005	apr	1,229,784	43,628	162,600	258	120	603	8.6	43.0	17.2	68.9	6.1	23.7	2.5	10.8
2005	may	1,323,417	58,051	144,500	278	66	648	9.3	46.3	18.5	74.1	6.6	25.5	2.6	11.6
2005	jun	1,295,058	45,184	150,600	272	119	635	9.1	45.3	18.1	72.5	6.5	24.9	2.6	11.3
2005	jul	1,205,506	71,949	125,500	253	97	591	8.4	42.2	16.9	67.5	6.0	23.2	2.4	10.5
2005	aug	1,132,556	83,718	97,700	238	90	555	7.9	39.6	15.9	63.4	5.7	21.8	2.3	9.9
2005	sep	1,268,415	70,067	133,200	266	121	622	8.9	44.4	17.8	71.0	6.3	24.4	2.5	11.1
2005	oct	1,151,756	41,330	159,400	242	117	564	8.1	40.3	16.1	64.5	5.8	22.2	2.3	10.1
2005	nov	1,038,621	52,563	138,400	218	102	509	7.3	36.4	14.5	58.2	5.2	20.0	2.1	9.1
2005	dec	995,838	49,308	153,100	209	83	488	7.0	34.9	13.9	55.8	5.0	19.2	2.0	8.7
2006	jan	919,103	44,421	165,600	193	77	450	6.4	32.2	12.9	51.5	4.6	17.7	1.8	8.0
2006	feb	722,666	32,712	150,100	152	71	354	5.1	25.3	10.1	40.5	3.6	13.9	1.4	6.3
2006	mar	741,875	46,344	160,700	156	73	364	5.2	26.0	10.4	41.5	3.7	14.3	1.5	6.5
2006	apr	941,944	50,437	149,000	198	92	462	6.6	33.0	13.2	52.7	4.7	18.1	1.9	8.2
2006	may	1,081,790	58,563	158,400	227	106	530	7.6	37.9	15.1	60.6	5.4	20.8	2.2	9.5
2006	jun	1,132,300	51,360	151,500	238	111	555	7.9	39.6	15.9	63.4	5.7	21.8	2.3	9.9
2006	jul	980,963	57,142	137,700	206	96	481	6.9	34.3	13.7	54.9	4.9	18.9	2.0	8.6
2006	aug	899,066	58,584	113,200	189	88	441	6.3	31.5	12.6	50.3	4.5	17.3	1.8	7.9
2006	sep	1,142,162	49,258	136,900	240	97	560	8.0	40.0	16.0	64.0	5.7	22.0	2.3	10.0
2006	oct	1,188,042	62,932	147,600	249	109	582	8.3	41.6	16.6	66.5	5.9	22.9	2.4	10.4
2006	nov	1,107,045	56,307	155,100	232	89	542	7.7	38.7	15.5	62.0	5.5	21.3	2.2	9.7
2006	dec	802,161	62,450	153,320	168	64	393	5.6	28.1	11.2	44.9	4.0	15.4	1.6	7.0

Annex 7
Raw Data for "Paper mills" WWTP
Source: Report submitted by Paper mills to Local agenda 21 Office in 2005

Parameter	Value
Inflow (m ³ year ⁻¹)	14,400,000
Energy consumption (Kwh)	744,971
Energy production (Kwh)	1,539,236
BOD in (kg)	2,596,051
Sludge (ton)	1,139
COD in (kg)	6,057,453
TP in (kg)	86,535
TN in (kg)	432,675
Heavy metals in (kg)	11,730
BOD out (kg)	173,070
COD out (kg)	692,280
TP out (kg)	61,811
TN out (kg)	237,971
Heavy metals out (kg)	3,499
TP sludge (kg)	24,724
TN sludge (kg)	108,169
Heavy metals sludge (kg)	8,231

Annex 8
Calculations of CO₂ emissions from electricity consumption

Energy source	Relative proportion of each source in Spain		Factors for CO ₂ emissions (g/kWh)	Resulting emissions (g/Kwh)	
	Current	Projections form National Energy Plan (2020)		Current	Projections form National Energy Plan (2020)
Coal	0.40	0.20	980	395.4	196.0
Hydropower	0.19	0.22	9	1.7	1.9
Combined cycles	0.09	0.33	362	33.3	119.5
Wind	0.04	0.06	7	0.3	0.4
Nuclear	0.27	0.19	20	5.4	3.7
Gas Thermal	0.00	0.00	653	0.0	0.0
Resulting factors for Spain				436.1	321.5

Source for Spain: Ministerio de Industria, Turismo y Comercio de España (2007)

Source for Emission Factors: European Commission (1995)

From previous annexes electricity consumptions per year can be obtained:

Total energy consumption per year (Gwh)						
Year	DWTP	Distribution network	Cartuja	Almozara	Groundwater extraction	Paper mills
2001	5.07	1.01	28.25	1.02	0.38	0.74
2002	5.08	0.91	28.69	0.67	0.38	0.74
2003	5.43	0.82	28.68	0.82	0.38	0.74
2004	6.51	0.65	29.03	0.82	0.38	0.74
2005	7.02	0.62	29.33	0.66	0.38	0.74
2006	6.74	0.60	28.99	0.63	0.38	0.74

When current emission factor for Spain (436.1 g/Kwh) is applied to the values of total energy consumption per year the CO₂ emissions are obtained:

CO ₂ emissions (ton)						
	DWTP	Distribution network	Cartuja	Almozara	Groundwater extraction	Paper mills
2001	2,210	442	12,315	443	164	325
2002	2,215	399	12,508	292	166	325
2003	2,369	355	12,506	358	165	325
2004	2,840	284	12,655	356	166	325
2005	3,059	271	12,789	287	164	325
2006	2,939	262	12,641	275	165	325

Annex 9. Calculation of Environmental Impacts from Transportation Energy consumed and CO₂ emissions

Total mass of chemical products and sludge per year at the different UWS facilities can be obtained from previous annexes.

Factors for CO₂ emissions and energy consumption derived from transportation of products in Heavy trucks where obtained from Thonstad (2005):

CO₂ emission factor (g/ton/km) = 69

Energy consumption factor (Kwh/ton/km) = 0.22

Distances between facilities and production companies (for chemical products) and between facilities and disposal sites (for sludge) were provided by the Local Agenda 21 Office of Zaragoza.

Total annual mass (ton)								
	DWTP				Cartuja		Almozara	Paper mills
Year	Chlorine	Alum	PAC	Sludge as Dry matter	Iron Chloride	Sludge as ash	Sludge	Sludge
2001	3,365	10,045	0	0	5,065	4,754	1,077	1,139
2002	2,974	9,090	0	3,489	4,843	4,640	1,112	1,139
2003	2,909	9,331	45	7,594	4,692	5,113	1,129	1,139
2004	3,074	9,840	337	5,995	4,681	3,698	1,240	1,139
2005	2,237	7,526	178	5,974	5,042	4,048	1,231	1,139
2006	2,456	5,989	179	7,674	4,763	4,135	1,073	1,139
Distance (km)	25	32	18	21	18	21	15	21
Resulting factors from multiplying distances								
CO ₂	1725	2208	1242	1449	1242	1449	1035	1449
Energy	5.5	7.04	3.96	4.62	3.96	4.62	3.3	4.62

The values for Energy consumption are the following:

Total energy consumption from transportation of sludge and chemical products (Kwh)								
	DWTP				Cartuja		Almozara	Paper mills
Year	Chlorine	Alum	PAC	Sludge as Dry matter	Iron Chloride	Sludge as ash	Sludge	Sludge
2001	18,508	70,714	0	0	20,057	21,965	3,555	5,264
2002	16,356	63,992	0	16,120	19,177	21,439	3,669	5,264
2003	15,997	65,692	178	35,082	18,579	23,622	3,726	5,264
2004	16,906	69,274	1,333	27,696	18,539	17,084	4,093	5,264
2005	12,305	52,984	704	27,600	19,968	18,701	4,064	5,264
2006	13,506	42,162	708	35,454	18,863	19,104	3,539	5,264

The values for CO₂ emissions are the following:

Total CO₂ emissions from transportation of sludge and chemical products (ton)								
	DWTP				Cartuja		Almozara	Paper mills
Year	Chlorine	Alum	PAC	Sludge as Dry matter	Iron Chloride	Sludge as ash	Sludge	Sludge
2001	5.8	22.2	0.0	0.0	6.3	6.9	1.1	1.7
2002	5.1	20.1	0.0	5.1	6.0	6.7	1.2	1.7
2003	5.0	20.6	0.1	11.0	5.8	7.4	1.2	1.7
2004	5.3	21.7	0.4	8.7	5.8	5.4	1.3	1.7
2005	3.9	16.6	0.2	8.7	6.3	5.9	1.3	1.7
2006	4.2	13.2	0.2	11.1	5.9	6.0	1.1	1.7

Annex 10. Calculations for Storm water overflows to the Ebro River

Year	Month	Precipitation (mm)	Precipitation * Impervious area	Expected from precipitation + consumption	Total Inflow WWTPs	Expected from consumption minus Total inflow WWTPs	Overflows to the river
2001	Jan	30	837,480	5,893,629	5,283,654	227,505	609,975
2001	Feb	4	105,840	4,561,242	4,750,549	295,147	0
2001	Mar	24	665,280	5,564,739	5,019,201	119,743	545,537
2001	Apr	7	198,800	4,854,963	5,959,424	1,303,262	0
2001	May	50	1,405,880	6,418,318	6,542,564	1,530,126	0
2001	Jun	8	213,080	5,869,981	6,599,078	942,178	0
2001	Jul	46	1,300,320	6,882,947	6,760,941	1,178,315	122,005
2001	Aug	4	113,400	5,522,964	6,382,140	972,577	0
2001	Sep	73	2,047,640	7,377,521	5,888,392	558,510	1,489,130
2001	Oct	17	482,440	5,743,443	6,244,635	983,632	0
2001	Nov	12	326,480	5,431,775	5,568,865	463,570	0
2001	Dec	0	0	5,411,588	5,450,557	38,968	0
2002	Jan	31	879,480	6,074,230	5,567,126	372,376	507,104
2002	Feb	6	177,240	4,488,013	5,203,145	892,372	0
2002	Mar	37	1,029,840	5,830,599	5,804,472	1,003,713	26,127
2002	Apr	26	731,360	5,095,437	5,721,607	1,357,530	0
2002	May	1	33,600	4,700,258	6,183,598	1,516,940	0
2002	Jun	14	397,600	5,434,335	5,770,842	734,107	0
2002	Jul	16	448,000	5,704,241	5,848,143	591,902	0
2002	Aug	9	252,000	4,989,296	5,481,357	744,061	0
2002	Sep	23	644,000	5,476,632	5,963,792	1,131,160	0
2002	Oct	38	1,052,800	5,908,543	6,087,789	1,232,046	0
2002	Nov	10	268,800	5,072,870	6,082,345	1,278,275	0
2002	Dec	21	599,200	5,368,205	5,235,784	466,778	132,422

Formula

Estimated storm water
= Precipitation * impervious area

Overflows = Estimated storm water +
Expected WWTPs inflow – Actual inflow to
WWTPs

Impervious area (km²) = 28,000

Year	Month	Precipitation (mm)	Precipitation * Impervious area	Expected from precipitation + consumption	Total Inflow WWTPs	Expected from consumption minus Total inflow WWTPs	Overflows to the river
2003	Jan	15	414,400	5,120,255	5,710,425	1,004,570	0
2003	Feb	33	918,400	4,978,424	4,953,460	893,436	24,964
2003	Mar	18	498,400	4,847,781	5,898,954	1,549,573	0
2003	Apr	29	812,000	4,805,901	6,782,711	2,788,810	0
2003	May	46	1,282,400	5,767,313	6,342,571	1,857,658	0
2003	Jun	39	1,103,200	5,954,054	6,442,952	1,592,098	0
2003	Jul	1	39,200	5,173,981	6,275,171	1,140,391	0
2003	Aug	4	112,000	5,034,663	5,987,821	1,065,159	0
2003	Sep	33	924,000	5,601,800	6,530,620	1,852,820	0
2003	Oct	44	1,226,400	5,982,163	6,668,779	1,913,016	0
2003	Nov	35	980,000	5,445,823	5,893,797	1,427,974	0
2003	Dec	16	448,000	5,073,223	5,745,564	1,120,341	0
2004	Jan	10	291,200	4,586,785	4,659,927	364,342	0
2004	Feb	34	957,600	4,925,772	5,297,399	1,329,227	0
2004	Mar	42	1,164,800	5,653,661	4,848,310	359,449	805,351
2004	Apr	35	968,800	5,076,606	5,856,635	1,748,829	0
2004	May	47	1,316,000	5,860,213	5,546,030	1,001,817	314,183
2004	Jun	10	274,400	5,344,331	7,059,872	1,989,941	0
2004	Jul	24	672,000	5,668,454	6,664,378	1,667,924	0
2004	Aug	2	44,800	4,587,888	6,043,663	1,500,574	0
2004	Sep	6	179,200	4,955,382	5,897,416	1,121,234	0
2004	Oct	28	784,000	5,449,262	6,719,082	2,053,820	0
2004	Nov	1	16,800	4,483,808	5,580,528	1,113,520	0
2004	Dec	0	0	4,439,115	5,856,758	1,417,643	0

Year	Month	Precipitation (mm)	Precipitation * Impervious area	Expected from precipitation + consumption	Total Inflow WWTPs	Expected from consumption minus Total inflow WWTPs	Overflows to the river
2005	Jan	10	275,800	4,787,355	5,630,561	1,119,006	0
2005	Feb	8	218,400	4,355,780	5,422,743	1,285,363	0
2005	Mar	17	476,000	4,932,419	6,121,835	1,665,416	0
2005	Apr	14	397,600	4,649,740	6,533,284	2,281,144	0
2005	May	50	1,394,400	5,799,473	7,030,717	2,625,644	0
2005	Jun	46	1,288,000	5,862,983	6,880,058	2,305,076	0
2005	Jul	0	5,600	4,633,128	6,404,306	1,776,778	0
2005	Aug	6	156,800	4,285,596	6,016,756	1,887,959	0
2005	Sep	22	610,400	4,902,997	6,738,515	2,445,918	0
2005	Oct	40	1,131,200	5,183,344	6,118,756	2,066,611	0
2005	Nov	33	912,800	4,836,312	5,517,721	1,594,209	0
2005	Dec	6	156,800	4,540,264	5,290,438	906,975	0
2006	Jan	16	453,600	4,834,733	5,206,163	825,030	0
2006	Feb	27	767,200	4,251,890	4,093,466	608,776	158,424
2006	Mar	13	364,000	4,258,136	4,202,275	308,139	55,861
2006	Apr	26	722,400	4,299,035	5,335,544	1,758,909	0
2006	May	16	453,600	4,718,791	6,127,690	1,862,499	0
2006	Jun	41	1,136,800	5,614,742	6,413,800	1,935,859	0
2006	Jul	38	1,052,800	5,567,399	5,556,563	1,041,963	10,837
2006	Aug	6	173,600	4,144,170	5,092,666	1,122,096	0
2006	Sep	61	1,719,200	5,876,446	6,469,662	2,312,416	0
2006	Oct	25	688,800	4,703,978	6,729,542	2,714,364	0
2006	Nov	43	1,204,000	5,028,348	6,270,745	2,446,397	0
2006	Dec	0	0	4,110,740	4,543,761	433,022	0